

# FINAL PLAN

## Northwest Arkansas Regional Waste Reduction & Recycling Optimization Study



May, 2021



Funding for this study was  
provided by  
**Boston Mountain Solid Waste  
Management District**  
&  
**Northwest Arkansas Council**

# TABLE OF CONTENTS

---

## *Acknowledgments*

<b>1. INTRODUCTION.....</b>	<b>1-1</b>
1.1 Background.....	1-1
1.2 Why Waste Reduction and Recycling are Necessary.....	1-2
1.3 Optimizing Recycling.....	1-3
1.4 Guiding Principles.....	1-4
1.5 Overview of Region.....	1-4
1.6 Stakeholder Participation.....	1-7
1.7 Report Organization.....	1-8
<b>2. RECYCLING STANDARDIZATION &amp; RECOVERY.....</b>	<b>2-1</b>
2.1 Overview.....	2-1
2.2 Market Conditions.....	2-1
2.2.1 Historical Context.....	2-1
2.2.2 Current Markets.....	2-2
2.2.3 Recyclables Processing Trends.....	2-4
2.3 Recycling Collection Programs.....	2-4
2.3.1 Curbside Collection.....	2-4
2.3.2 Drop-Off Recycling and Citizen Convenience Centers.....	2-8
2.3.3 Commercial Recycling Collection.....	2-8
2.4 Recycling Economics.....	2-9
2.4.1 Residential Recycling Programs.....	2-9
2.4.2 Contractual Arrangements.....	2-9
2.4.3 Markets in and Around Northwest Arkansas.....	2-10
2.5 Current Processing Facilities.....	2-12
2.6 Vision for a Regional Recycling System.....	2-13
2.6.1 Standardization of Recycling Materials and Outreach.....	2-14
2.6.2 Migration to Standardized Curbside Collection Service.....	2-15
2.6.3 Development of Regional Recyclables Processing Infrastructure.....	2-16
2.6.4 Other Processing Options.....	2-18
2.7 Governance of a Regional Recycling System.....	2-20
2.7.1 Management and Funding.....	2-20
2.7.2 Contracting.....	2-21
2.7.3 Facility Ownership.....	2-22
2.8 Other Recycling Standardization Recommendations.....	2-22
<b>3. ORGANICS RECOVERY POTENTIAL.....</b>	<b>3-1</b>
3.1 Introduction to Organics Recovery.....	3-1
3.1.1 Processing and Collection Technologies.....	3-1

# TABLE OF CONTENTS

---

3.1.2	Organics Collections and Processing in Northwest Arkansas .....	3-2
3.2	Market Conditions .....	3-3
3.2.1	Current Market Drivers.....	3-4
3.2.2	Co-Location Trends .....	3-4
3.2.3	Economy of Scale.....	3-4
3.2.4	Quality standards .....	3-4
3.2.5	Demand in Northwest Arkansas .....	3-5
3.3	Current Collection and Processing Programs.....	3-5
3.3.1	City of Fayetteville Compost Facility .....	3-5
3.3.2	Eco-Vista Landfill and Compost Facility.....	3-7
3.3.3	City of Bentonville Compost Facility.....	3-8
3.3.4	Benton County Solid Waste District Yard Waste Facility .....	3-9
3.4	Vision for a Regional System.....	3-10
3.4.1	Regional Facility Analysis.....	3-10
3.4.2	Organics Generator Assessment .....	3-10
3.4.3	Organics Scenario 1: New Regional Organics Program.....	3-11
3.4.4	Organics Scenario 2: Expansion of Existing Processing Facilities .....	3-13
3.5	Other Organics-Related Recommendations .....	3-13
3.5.1	Organics Processing .....	3-13
3.5.2	Organics Collections.....	3-14
3.5.3	Additional Recommendations .....	3-14
<b>4.</b>	<b>C&amp;D RECOVERY POTENTIAL .....</b>	<b>4-1</b>
4.1	Introduction to C&D Recovery.....	4-1
4.2	Market Conditions .....	4-1
4.2.1	C&D Disposal and Composition .....	4-1
4.2.2	C&D Recycling and Reuse.....	4-2
4.3	Current Collection Programs .....	4-3
4.4	Current Processing Facilities .....	4-3
4.5	Enhancing Regional C&D Diversion.....	4-4
4.5.1	Tools and Strategies to Divert C&D Debris from Landfill.....	4-4
4.5.2	Mixed C&D Recycling Infrastructure .....	4-8
4.6	C&D Diversion Recommendations .....	4-10
4.6.1	Initial Needs .....	4-10
4.6.2	Expand SWD Role in C&D Diversion Organization.....	4-10
4.6.3	Implement Ordinance and Policy Changes .....	4-11
<b>5.</b>	<b>POTENTIAL RECOVERY SCENARIOS .....</b>	<b>5-1</b>
5.1	Introduction.....	5-1
5.2	Recycling Recovery .....	5-3
5.2.1	Recycling Standards (RS).....	5-3
5.2.2	Regional Recyclables Processing (RP).....	5-6
5.2.3	Drop-Off Convenience Centers (RC).....	5-9



# TABLE OF CONTENTS

5.2.4	HHW Services (RC).....	5-10
5.2.5	Recyclables Collection (RC).....	5-11
5.2.6	Summary Recommendations .....	5-13
5.3	Organics Recovery (Org) .....	5-15
5.4	C&D Recovery (CD) .....	5-17
5.4.1	Regulatory and Policy Changes.....	5-18
5.4.2	Regional Processing.....	5-20
<b>6.</b>	<b>IMPLEMENTATION CONSIDERATIONS .....</b>	<b>6-1</b>
6.1	Introduction.....	6-1
6.2	Overarching Considerations.....	6-1
6.2.1	Regional Cooperation.....	6-1
6.2.2	Sensitivity Towards Standard Recycling Collection .....	6-1
6.2.3	Widespread Acceptance of Stronger Regulatory Measures and Higher Costs .....	6-2
6.2.4	Long-term vs. Short-term Evaluation of Diversion over Landfill.....	6-2
6.3	Implementation Timing .....	6-3
6.3.1	Ongoing Actions.....	6-4
6.3.2	Actions in Years 1 and 2 .....	6-4
6.3.3	Actions in Years 3 and 4 .....	6-5
6.3.4	Actions in Years 5+.....	6-5
6.4	Next Steps .....	6-6

## LIST OF APPENDICES

- Appendix A – Baseline Report
- Appendix B – Project Information Flyer
- Appendix C – Initial Stakeholder Presentation
- Appendix D – Preliminary Findings – Presentation to Stakeholders
- Appendix E – Stakeholder Survey Results

# TABLE OF CONTENTS

---

## List of Figures

Figure 1-1 Northwest Arkansas Regional Map .....	1-1
Figure 1-2 EPA Materials Management Hierarchy.....	1-2
Figure 1-3 Northwest Arkansas Historical and Projected Tonnage by Material Type.....	1-6
Figure 1-4 Northwest Arkansas Historical and Projected Tonnage by District.....	1-6
Figure 1-5 Current Diversion Summary (2018).....	1-7
Figure 2-1 Historical Value of Recyclables Midwest Region Pricing 2010-2020 .....	2-2
Figure 2-2 Recycling Contamination Trends (State of Florida).....	2-3
Figure 2-3 Curbside Recycling Collection Methods .....	2-5
Figure 2-4 Recycling Collection and Processing Contract Expirations and Optional Extensions.	2-10
Figure 2-5 Facilities within 100 Miles of Tri-County Centroid.....	2-12
Figure 2-6 Marck Industries Recycling Facility .....	2-13
Figure 2-7 Conceptual Multi-Stream Processing Facility Schematic.....	2-18
Figure 2-8 Mini MRF Schematic for the Revolution System.....	2-20
Figure 3-1 2018 Organic Material Diversion in Northwest Arkansas Region.....	3-3
Figure 3-2 City of Fayetteville Compost Facility.....	3-6
Figure 3-3 Eco-Vista Landfill & Compost Facility.....	3-7
Figure 3-4 City of Bentonville Compost Facility .....	3-8
Figure 4-1 Estimated C&D Waste Composition by Major Material Group (2018) .....	4-2

## List of Tables

Table 1-1 Current and Projected Demographics .....	1-5
Table 1-2 Recyclables and Organics in Northwest Arkansas Waste Stream.....	1-7
Table 1-3 Stakeholder Engagement Summary .....	1-8
Table 2-1 Recycling Commodity Destinations 2017-2020 .....	2-2
Table 2-2 Municipal Recycling Collection Program Distribution in Northwest Arkansas.....	2-5
Table 2-3 Average Curbside Recycling Performance (Annual Pounds per Household).....	2-6
Table 2-4 NW Arkansas Curbside Recycling Performance (2018 Pounds Diverted per HH) .....	2-6
Table 2-5 NW Arkansas Curbside Recycling Performance (2018 Pounds Diverted per HH) .....	2-7
Table 2-6 Projected Quantity of Fiber and Container Recyclables in Northwest Arkansas .....	2-7
Table 2-7 Northwest Arkansas Recycling Drop-offs and Citizen Convenience Centers .....	2-8
Table 2-8 Blended Market Value for Generic Single-Stream Mix.....	2-11
Table 2-9 Blended Market Value for a Generic Curb-sort Mix.....	2-11
Table 2-10 Regional MRF Processing Fees (2019) .....	2-13
Table 2-11 Basic and Expanded Standardized Recyclables Material List.....	2-14
Table 2-12 Pros and Cons of Recycling Collection Options .....	2-15
Table 2-13 Regional Recyclables Processing Options.....	2-17
Table 2-14 Options for Central Management for Municipal Contracts .....	2-22
Table 3-1 Potential Composting Technologies .....	3-1

# TABLE OF CONTENTS

Table 3-2	Yard Waste Collection Programs in Northwest Arkansas.....	3-2
Table 3-2	City of Fayetteville Compost Facility Program Overview .....	3-6
Table 3-3	Eco-Vista Landfill Yard Waste Compost Facility Program Overview .....	3-8
Table 3-4	City of Bentonville Compost Facility Program Overview.....	3-9
Table 3-5	Benton County Solid Waste District Regional Compost Facility Program Overview .....	3-9
Table 3-6	Organics Generator Assessment Results (Annual Tonnage by Sector).....	3-11
Table 3-7	Regional Composting Facility Pro Forma Calculation Assumptions.....	3-11
Table 3-8	Regional Composting Facility Financial Estimates.....	3-12
Table 4-1	Estimated Regional C&D Waste Composition (2018).....	4-2
Table 4-2	C&D Recycling Facilities in NWA (ADEQ Database Search Results).....	4-3
Table 4-3	Sample Thresholds for Submittal of a C&D Recycling Plan.....	4-5
Table 4-4	Regional C&D Data Needs from Enhanced Reporting .....	4-5
Table 4-5	Sample Diversion Requirements .....	4-6
Table 4-6	Cities with a C&D Recycling Deposit Program .....	4-6
Table 4-7	Summary of C&D Diversion Strategies .....	4-8
Table 4-8	Mixed C&D Recycling Facility Capital Cost Estimate.....	4-9
Table 5-1	Scenario Summary .....	5-2
Table 5-2	Key Findings: Recycling Standardization (RS) .....	5-3
Table 5-3	Scenario RS-1: Maintain Status Quo for Recycling Standards .....	5-4
Table 5-4	Scenario RS-2: Designate Districts to Develop Recycling Standards .....	5-5
Table 5-5	Scenario RS-3: Designate Development of Standards to a Regional Authority.....	5-5
Table 5-6	Key Findings: Regional Management of Recyclables Processing (RP).....	5-6
Table 5-7	Scenario RP-1: Maintain Status Quo (Leave Processing to Market Forces) .....	5-7
Table 5-8	Scenario RP-2: Designate Districts to Expand Processing Capacity .....	5-8
Table 5-9	Scenario RP-3: Create a Single Regional Entity to Expand Processing Capacity.....	5-9
Table 5-10	Scenario RC-3: Expand Recycling Drop-off Access in Madison County .....	5-10
Table 5-11	Scenario RC-4: Expand HHW Disposal Access.....	5-10
Table 5-12	Key Findings: Recyclables Collection (RC).....	5-11
Table 5-13	Scenario RC-1: Migrate to Single Stream Collection .....	5-12
Table 5-14	Scenario RC-2: Migrate to Regional Dual Stream Collection.....	5-13
Table 5-15	Supporting Regional Recycling Recommendations .....	5-14
Table 5-16	Organics Recovery Key Findings (Org) .....	5-15
Table 5-17	Scenario Org-1: Develop New Regional Organics Program.....	5-15
Table 5-18	Scenario Org-2: Expand Existing Organics Processing Facilities and Programs.....	5-16
Table 5-19	Supporting Organic Recovery Recommendations.....	5-17
Table 5-20	Key Findings: Increasing Diversion of Construction & Demolition Debris (CD) ....	5-18
Table 5-21	Scenario CD-1: Implement Voluntary C&D Diversion Programs .....	5-18
Table 5-22	Scenario CD-2: Implement Mild C&D Diversion Regulatory Requirements .....	5-19
Table 5-23	Scenario CD-3: Implement Aggressive C&D Diversion Regulatory Requirements ...	5-20
Table 5-24	Scenario CD-4: Develop Regional C&D Processing Infrastructure.....	5-21
Table 6-1	Timing and Duration of Supporting Actions for Identified Strategies.....	6-3

This page intentionally left blank.

## ACKNOWLEDGEMENTS

---

This project was made possible by the management and financial support of the following organizations:

- ◆ Boston Mountain Solid Waste Management District
- ◆ Northwest Arkansas Council

Additionally, the Project Team would like to thank the following parties for their assistance during various stages of this project:

- ◆ Arkansas Department of Energy and Environment - Division of Environmental Quality
- ◆ Benton County Solid Waste Management District
- ◆ Benton County
- ◆ CARDS Recycling
- ◆ City of Bella Vista
- ◆ City of Bentonville
- ◆ City of Centerton
- ◆ City of Farmington
- ◆ City of Fayetteville
- ◆ City of Pea Ridge
- ◆ City of Prairie Grove
- ◆ City of Rogers
- ◆ City of Siloam Springs
- ◆ City of Springdale
- ◆ City of Tontitown
- ◆ Food Loops
- ◆ Madison County
- ◆ Marck Industries
- ◆ University of Arkansas Office of Sustainability and Facilities Management
- ◆ Washington County
- ◆ Waste Management
- ◆ Walmart

This study would not have been successful without the support and cooperation of these regional stakeholders.

This page intentionally left blank.



# 1. INTRODUCTION

## 1.1 BACKGROUND

In 1991, the Arkansas Legislature passed Act No. 752 establishing Solid Waste Management Districts to oversee solid waste management activities in a single or multi-county region. The Boston Mountain Solid Waste District (BMSWD) includes Washington and Madison counties, and the Benton County Solid Waste District (BCSWD) oversees Benton County. Both Districts provide various programs and facilities to manage material streams for each District's constituents. Each District is governed by a Board of Directors consisting of elected officials and staff from the municipalities and counties within the District. Collectively, these two Districts span the Northwest Arkansas region, as shown in Figure 1-1.

**Figure 1-1 Northwest Arkansas Regional Map**

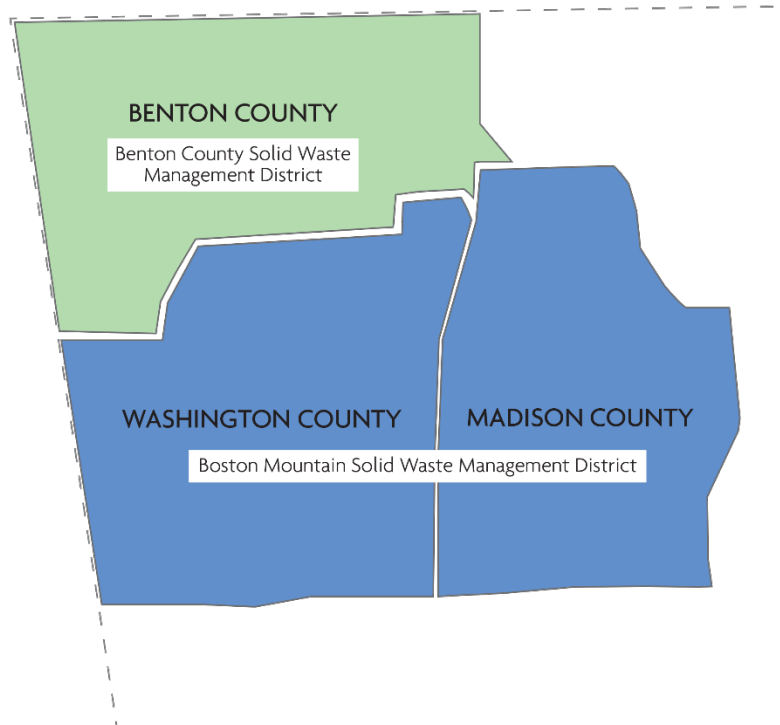

The Districts work in collaboration with (among others) incorporated cities, which also have a vested interest in the evolution of recycling and waste management services. Cities in Arkansas are charged with the provision of waste and recycling collection services, and some cities also have waste management facilities to serve their constituents. Cities are serving in many regards as a direct utility for the provision of waste management and recycling services, with the ability to directly charge customers to fund collection, recycling, composting and disposal services.

Finally, corporations and institutions in the region, intent on attracting top talent to support their businesses and top students to bolster their standing and further seed the economy, have identified the importance of meeting the needs and expectations of this desired community. One such expectation is that there will be a robust recycling and waste reduction ethic, with access to effective programs for diverting material from landfill by recycling commodities and nutrients back into the regional and national economy. There are numerous options for establishing such programs and optimizing recycling and diversion.

# INTRODUCTION

## 1.2 WHY WASTE REDUCTION AND RECYCLING ARE NECESSARY

Waste reduction (or “source reduction”) refers to eliminating waste before it is generated and is the generally preferred method for managing solid waste. Source reduction can include a wide range of market-based or state and local policy actions and strategies and involve the design, manufacture, purchase or use of materials and products in order to reduce the amount (and toxicity) of waste generated.

On a generation per-capita basis, waste reduction has already been occurring in many parts of the U.S. during the past 10 years due in large part to consumer product and packaging redesigns that reduce the amount of materials used. Perhaps the biggest examples of waste reduction have occurred through the emergence of digital media and publishing, which have led to sharp declines in the generation of paper.

Recycling is defined by Arkansas Regulation No.28 as the systematic collection, sorting, decontamination, and returning of solid waste materials to commerce as commodities for use or exchange. For the purpose of this evaluation, organics diversion through composting or other method is included in the definition of recycling. Waste reduction and recycling are important to conserve landfill space, prolong the need for landfill expansions and new landfills, minimize the cost to manage end-of-life materials, and reduce pollution and toxicity through better lifecycle management. The preference for waste reduction and recycling are captured in the U.S. Environmental Protection Agency’s materials management hierarchy, shown in Figure 1-2.

Figure 1-2 EPA Materials Management Hierarchy

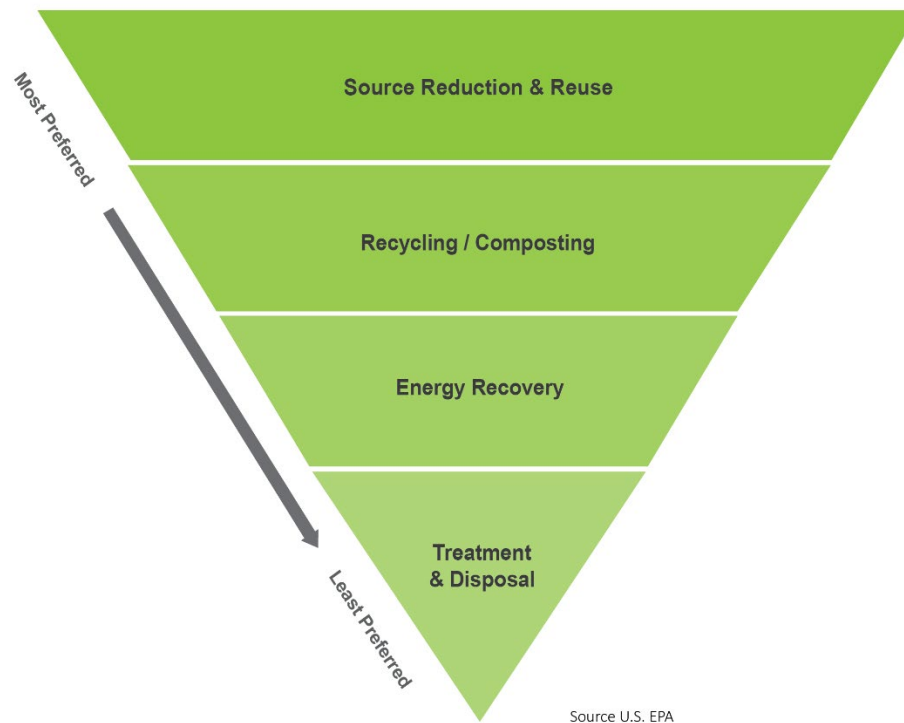

At the state and local government program level, waste reduction initiatives have traditionally focused on public education to encourage actions such as buying in bulk, using reusable shopping bags, starting to backyard compost, and encouraging reuse and donation of household goods and textiles. Bans and fees on single-use plastic bags are policy actions that can be taken to reduce waste (as well as litter).

Recycling is popular and the concept of reusing materials rather than burying them in a landfill is appealing. Some regions of the country have evolved highly successful recycling programs that divert half of the

waste stream. These regions benefit from their robust recycling programs, which contribute to a favorable environmental standard of living due to environmental stewardship.

Under the leadership of the Districts,<sup>1</sup> the region identified the need to look more closely at its waste management system, with particular attention on optimizing policies, systems and infrastructure that would increase the diversion of materials away from landfill disposal.

## 1.3 OPTIMIZING RECYCLING

The Project Team of MSW Consultants and Kessler Consulting, Inc. (KCI) was retained to undertake a regional waste reduction and recycling optimization study in collaboration with the Districts and other stakeholders.<sup>2</sup> Based on input from District staff and project funders, this initiative targeted three major components of the regional materials management system to be optimized to create a platform for long-term evolution and growth. The major components of this initiative were determined to be:

- ◆ Development of **regional recyclables processing capacity** and path to **standardized recycling**. The region currently has a mix of recycling program configurations (e.g. curb sort and single stream), and the targeted materials are not consistent from program to program. Further, to fully maximize diversion, the industrial capacity needed to process recyclables from the region will have to increase (or else mixed recyclables will need to be transported out of the region at greater expense and at a loss of material quality). This waste reduction and recycling initiative sought to identify a long-term path to expand processing capacity and evolve regional recycling programs to a more uniform standard.
- ◆ Evaluation of **regional organics diversion** potential. Food scraps and yard wastes make up a significant fraction of the materials being disposed in the region at the current time. Similar to increasing the recycling of fiber, bottles and cans, organics diversion can be increased through the development of organics collection and processing capacity and associated changes to programs to separate and divert organic materials. This initiative conceptualized a path towards developing and scaling up diversion of organics.
- ◆ Evaluation of **construction and demolition (C&D) material diversion** potential. Finally, C&D debris contains a significant fraction of recoverable materials. Although some source separation and recycling of C&D debris is occurring now, this initiative identified policies, programs, and incentives for increasing C&D diversion and potentially leveraging public-private partnerships to establish mixed C&D processing within the region (as is currently the case in other regions of Arkansas).

Finally, it was recognized that expansion to the rural convenience center infrastructure would likely be necessary to make sure that all residents across the region have convenient access to waste disposal, recycling, organics diversion, and environmentally sound household hazardous waste disposal. The approaches taken for these initiatives are discussed in detail throughout the remainder of this report.

---

<sup>1</sup> This project was funded by the Boston Mountain Solid Waste District, with supplemental funding for the recycling component from the Northwest Arkansas Council on behalf of the Benton County Solid Waste District.

<sup>2</sup> It is noted that The Sustainability Consortium (TSC) recently completed the Northwest Arkansas Circular Economy Project, a separate initiative that involved many of the waste management and recycling stakeholders in the region. TSC is a global non-profit organization whose stated mission is “to transform the consumer goods industry by partnering with leading companies to define, develop, and deliver more sustainable products.” The Northwest Arkansas Circular Economy Project evaluated the role the business community can play in optimizing recycling, while this recycling optimization study addresses recycling from the standpoint of the Districts and local governments that are largely responsible for material end-of-life management under current state and federal laws and regulations. The two initiatives are highly complementary.

# INTRODUCTION

---

## 1.4 GUIDING PRINCIPLES

The participating SWMDs embrace the recycling and circular movement of valuable recovered materials as a critical component in the sustainable economic development and environmental protection of Northwest Arkansas. Consequently, these SWMDs recognize the importance of establishing a thoughtful process for coordinated regional development of the infrastructure, policies, and markets to advance sustainable materials management in the region.

Of equal importance, the SWMDs recognize that developing a successful regional solution must accommodate the values and goals of the numerous stakeholders in the region. This waste reduction and recycling analysis was guided by the following principles:

- ◆ **Affordable and Financially Sound:** The optimal solution should not impose any undue financial burden on any single stakeholder or group of stakeholders as a basis to reach fruition and should establish reasonable incremental increases to the overall cost of managing wastes, recyclables, and organics within the region.
- ◆ **Guided by Commercially Proven Technology:** The development of new facility infrastructure or changes to methods for collecting materials within the region should focus on proven technology, incorporating modern design and operational capabilities, with high probability for commercial success.
- ◆ **Market-savvy:** Recycling, composting, and other forms of recovering materials to avoid landfilling should be pursued to the extent there is a viable path to these processes functioning within a healthy local, regional, or wider market.
- ◆ **Encompassing of All Stakeholders:** Local governments, institutions, citizens, and the many private sector businesses that create our vibrant economy should be invited to participate in the process.
- ◆ **Voluntary:** While a regional system stands to benefit all over the long term, the system must enable stakeholders to determine when and to what extent they wish to participate.

This project was undertaken with these guiding principles in mind.

## 1.5 OVERVIEW OF REGION

The Northwest Arkansas region is among the fastest growth regions in the nation. Benton, Madison and Washington counties comprise the area included in this planning process, an area of 37 municipalities and townships as well as the unincorporated population. The most recent demographic information for the region is provided in Table 1-1 along with growth projections based on data provided by the Arkansas Economic Development Institute. As shown, the 2020 estimated population for the three counties is nearly 560,000, and high growth is projected to continue for the next 10 years. Although not shown in the table, the Northwest Arkansas Regional Planning Commission projects that Benton and Washington counties will have 975,000 residents by 2045.

**Table 1-1 Current and Projected Demographics**

District	Parameter	2010	2018	2020	2025	2030
Benton	Population	221,339	273,588	288,768	327,217	369,305
	Single-family Households	65,024	80,373	84,833	97,094	111,128
	Multi-family Households	15,711	19,419	20,497	23,459	26,850
Boston Mountain	Population	218,782	255,863	270,809	310,100	353,425
	Single-family Households	57,502	67,024	71,075	82,347	95,464
	Multi-family Households	23,087	27,206	28,947	33,800	39,467
<b>Combined</b>	<b>Total Population</b>	<b>440,121</b>	<b>529,451</b>	<b>559,577</b>	<b>637,317</b>	<b>722,731</b>
	Total Single-family Households	122,526	147,397	155,908	179,441	206,592
	Total Multi-family Households	38,797	46,626	49,443	57,259	66,317

Sources:

Arkansas Economic Development Institute. *Time Series Extrapolations, 2014-2065 – Vintage 2010 (based on Census 2010)*.

Benton County Solid Waste District. *2018 Regional Needs Assessment*.

Boston Mountain Regional Solid Waste Management District. *2018 Regional Needs Assessment*.

U.S. Census Bureau. *2017 American Community Survey 1-Year Estimates*.

U.S. Census Bureau, Population Division. *Annual Estimates of the Resident Population: April 1, 2010 to July 1, 2018*.

With a growing population comes an increase in waste generated that will either be disposed or recovered if programs are available and affordable. Figure 1-3 provides historic and projected generation of municipal solid waste (MSW) and C&D tonnage for the region, and Figure 1-4 provides the same projection with wastes divided by District. As shown, the continued population growth directly contributes to an increase in waste generation, with total tonnage increasing from less than 500,000 tons in 2020 to over 650,000 tons in 2030. High growth in waste generation increases the importance of developing a sound regional strategy for waste diversion and recycling.

# INTRODUCTION

**Figure 1-3 Northwest Arkansas Historical and Projected Tonnage by Material Type**

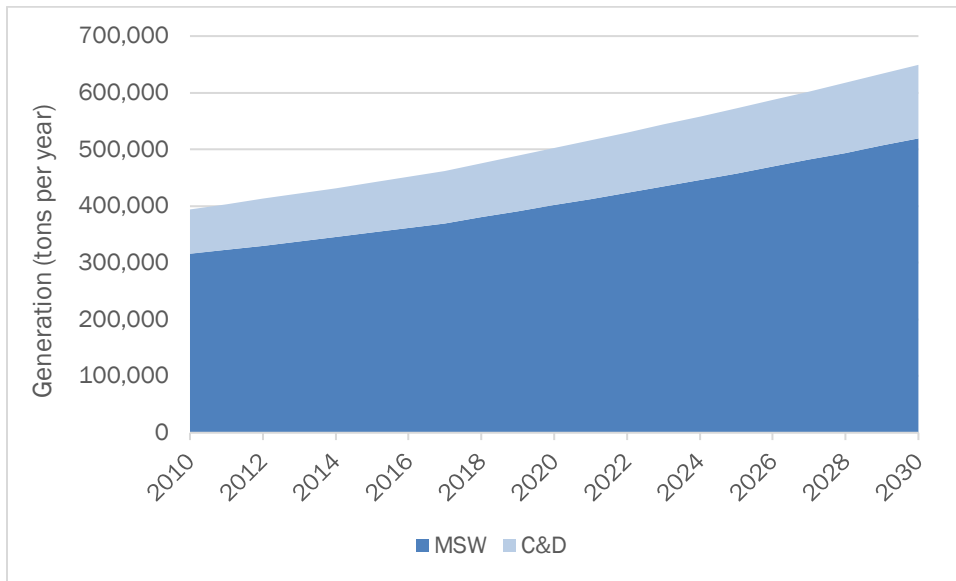

Generation calculated from actual tonnage data from six cities in the region applied to historical and projected population. C&D waste assumed to be 20% of total generation based on findings of recent midwestern waste characterization studies.

**Figure 1-4 Northwest Arkansas Historical and Projected Tonnage by District**

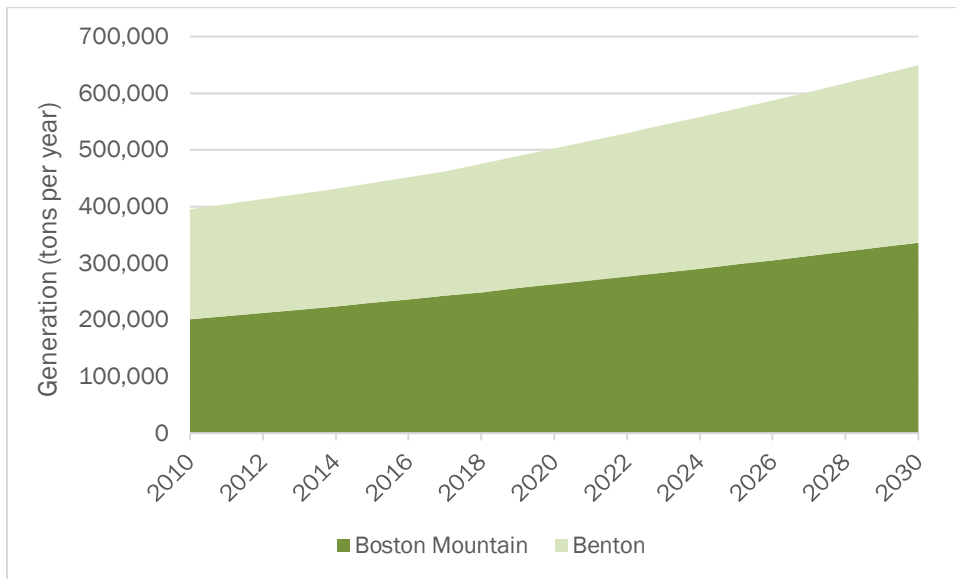

Municipal solid waste is mostly collected from residential homes and commercial establishments. The current diversion of recyclables and organics for the region is shown in Figure 1-5. As shown, only about 16 percent of the municipal solid waste generated in the region is diverted from disposal.



Figure 1-5 Current Diversion Summary (2018)

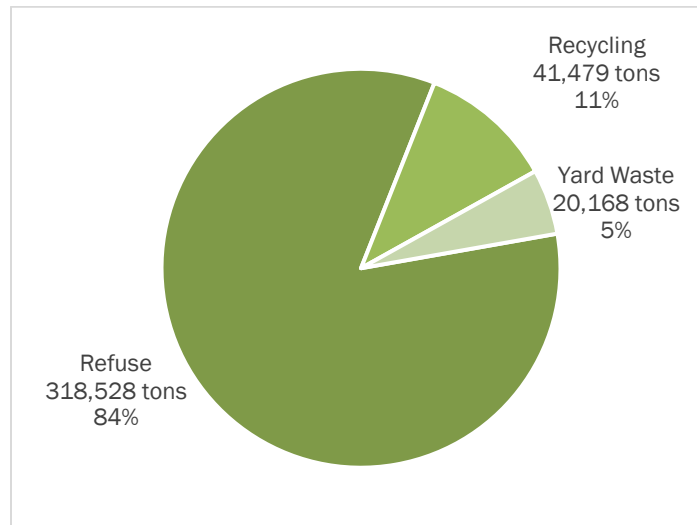

Of the recoverable materials remaining in the disposed waste stream, a significant fraction are recyclables or compostable organics. Table 1-2 illustrates the recyclables and organics in the waste stream, the associated capture rate and projected tonnage that is used throughout the WRRP with respect to planning for infrastructure needed to manage higher diversion.

Table 1-2 Recyclables and Organics in Northwest Arkansas Waste Stream

	Landfilled Tons [1]	Diverted Tons [2]	Total Generated Tons	Current Capture Rate[3]	Assumed Potential Feedstock	Processing Capacity Design (tons)[4]
Recyclables Fiber & Containers	76,068	41,479	117,547	35%	50%	70,528
Food Scraps	49,464	0	49,464	0%	30%	17,807
Green Wastes	8,841	20,168	29,009	70%	30%	10,443
Other Compostable Organic Materials	27,799	0	27,799	0%	30%	10,007

[1] Material estimated within the 2018 refuse stream based on compositional analysis.

[2] Material estimated within the recycling and yard waste streams based on available per-household generation rates then applied to projected population. Note: includes any weight resulting from contaminants.

[3] Weight of a material group collected for diversion (not including contaminants) divided by the weight of all of that material group in the waste stream.

[4] Assuming design at 120% of tons identified to feasibly be captured for diversion.

A Baseline Report containing additional details about the methodology used to estimate and project waste generation and composition as shown above is included in Appendix A.

## 1.6 STAKEHOLDER PARTICIPATION

This engagement incorporated significant outreach to understand the current system dynamics and to seek input from regional stakeholders. The Project Team and the Districts worked in collaboration to conduct the following activities to outreach and engage regional stakeholders:

- ◆ Distributed an informational flier, shown in Appendix B.

# INTRODUCTION

- ◆ Presented an overview of the project to a group meeting of stakeholders in a PowerPoint shown in Appendix C.
- ◆ Visited materials management facilities in the region, as shown in Table 1-3.
- ◆ Participated in individual meetings and interviews with regional stakeholders, as shown in Table 1-3.
- ◆ Attended a presentation by The Sustainability Coalition (TSC), a non-profit research group that was also evaluating opportunities to increase recycling in the region.
- ◆ Delivered preliminary findings about regional diversion and recycling opportunities to the stakeholder group in a PowerPoint contained in Appendix D.
- ◆ Distributed a survey to 43 public sector stakeholders to obtain feedback on recycling opportunities, with survey results contained in Appendix E.

**Table 1-3 Stakeholder Engagement Summary**

Meetings		Facility Site Visits
Public Sector	Private Sector	
Bella Vista	CARDS Recycling	Benton County Solid Waste District Recycling Center
Bentonville	Food Loops	Boston Mountain Solid Waste District Transfer Station, Recycling Drop-off and HHW Facility
Centerton	Marck Industries	City of Fayetteville Compost Facility
Farmington	Walmart	City of Greenland Recycling Center
Fayetteville	Waste Management	City of Rogers Recycling Center
Madison County		City of Siloam Springs Transfer Station and Recycling Drop-off
Prairie Grove		Marck Industries Material Recovery Facility
Rogers		University of Arkansas Facilities Recycling Operation
Springdale		
Tontitown		

The outreach conducted as part of this project, along with other regional initiatives such as the TSC’s Northwest Arkansas Circular Economy Project, have established a baseline level of collaboration that will be important as the region advances its recycling initiatives.

## 1.7 REPORT ORGANIZATION

The remainder of the report includes development of the three initiatives and recommendations for planning over the future decade in the following chapters:

- ◆ **Chapter 2 – Recycling Standardization & Recovery:** This section contains a comprehensive discussion of current recycling markets, economics, challenges with managing contamination, an inventory of recycling in Northwest Arkansas at the current time, and the potential to increase recycled tonnages under optimized programs. The section offers ideas and prerequisites to standardize regional recycling programs and provides planning level comparisons of various options to expand recyclables processing capacity.
- ◆ **Chapter 3 – Organics Recovery Potential:** This section describes proven organics processing technologies, inventories the current organics management infrastructure in Northwest Arkansas, and addresses two primary scenarios to develop the region’s organics management system.

- ◆ **Chapter 4 – C&D Recovery Potential:** This chapter provides information about the significant potential for C&D diversion, describes the current C&D recycling infrastructure, and introduces a series of increasingly aggressive policies and programs for increasing C&D recycling in the Boston Mountain SWD. The section also discusses mixed C&D processing infrastructure, market considerations, and costs.
- ◆ **Chapter 5 – Potential Recovery Scenarios:** This section organizes the information from the preceding sections into a series of scenarios for consideration by the region's stakeholders. Scenarios are provided in tabular format that includes a description of the scenario, a set of supporting actions, and identification of one or more outcomes if the scenario is implemented. This chapter also contains an extensive list of supporting recommendations.
- ◆ **Chapter 6 – Implementation Considerations:** The final chapter comments on the initial steps to implementing the findings from this initiative, sets expectations regarding the duration and timing of some of the more aggressive scenarios, and identifies the initial recommendations that can be immediately adopted to maintain momentum on regional recycling and waste reduction.
- ◆ **Appendices:** Stakeholder presentations, baseline reports and other project details are incorporated in several appendices.

This page intentionally left blank.

## 2. RECYCLING STANDARDIZATION & RECOVERY

---

### 2.1 OVERVIEW

Recycling within the residential and commercial sectors is well established in Northwest Arkansas. Large cities offer residential curbside recycling collection programs, and both SWMDs and some small cities have established recycling drop-off centers which are well-liked by the local population.

Similarly, the commercial and institutional sectors in Northwest Arkansas are committed to effective recycling programs. This commitment not only applies to recycling within individual corporate/business establishments and institutions which see such activity as both a revenue center for large volumes of recyclable materials, but it also extends to a desire that the region be capable of providing progressive, full-service residential recycling programs. Feedback received from business stakeholders identified that the region's economic growth hinges on the ability of businesses and institutions to recruit a talented workforce from across the U.S., and that this workforce expects there to be effective, widespread recycling programs in place across the residential sector.

The most effective recycling programs are uniform, easy to understand by residential and commercial generators, cost-effective to implement, and supported by fair and sustainable funding mechanisms. However, recycling programs across the region are not uniform in the materials they accept, nor in the method of set-out and collection, which complicates regional education and outreach initiatives. Further, and of primary importance, there is not sufficient recyclables processing infrastructure within the region to accommodate the volume of recyclables that are currently generated or projected with future population and business growth.

---

*The most effective recycling programs are uniform, easy to understand by residential and commercial generators, cost-effective to implement, and supported by fair and sustainable funding mechanisms.*

---

This section describes the current broad mix of recycling collection programs in the region which increase the complexity of establishing an optimized regional recycling system, as well as the associated limitations to processing recyclables that are collected. Feedback received at the initial meeting of District and local government stakeholders in February 2020 (pre-COVID) confirm that there is little political will to quickly change existing municipal collection systems, and therefore any regional plan must be flexible enough to accommodate current collection programs while allowing such programs to evolve over time as circumstances warrant.

This section also describes the current infrastructure for processing recyclables and introduces an overarching goal to develop a material recovery facility (MRF) capable of serving the region now, as well as into the future. Alternatives to a regional MRF are identified in this chapter but not evaluated in as much detail.

### 2.2 MARKET CONDITIONS

#### 2.2.1 HISTORICAL CONTEXT

The markets for the sale of recycled commodities are global, and over the past 20 years have fluctuated dramatically. Swings have been significant in the past three years, with the value of curbside recyclables in the entire U.S. shrinking from over \$5.5 billion in early 2017 to roughly \$2.8 billion at the end of 2019, a drop of nearly 50 percent.<sup>1</sup> Perhaps not surprisingly, recycling programs have struggled (and a few have been suspended) during down markets, despite flourishing in periods when market pricing was strong. As shown in Figure 2-1, most primary recycling commodities have been volatile over the past decade. For

---

<sup>1</sup> The Recycling Partnership: "2020 State of Curbside Recycling"

# RECYCLING STANDARDIZATION & RECOVERY

large-volume commodities, such as corrugated containers, a value swing of a few dollars can impact operational finances significantly.

Figure 2-1 Historical Value of Recyclables Midwest Region Pricing 2010-2020

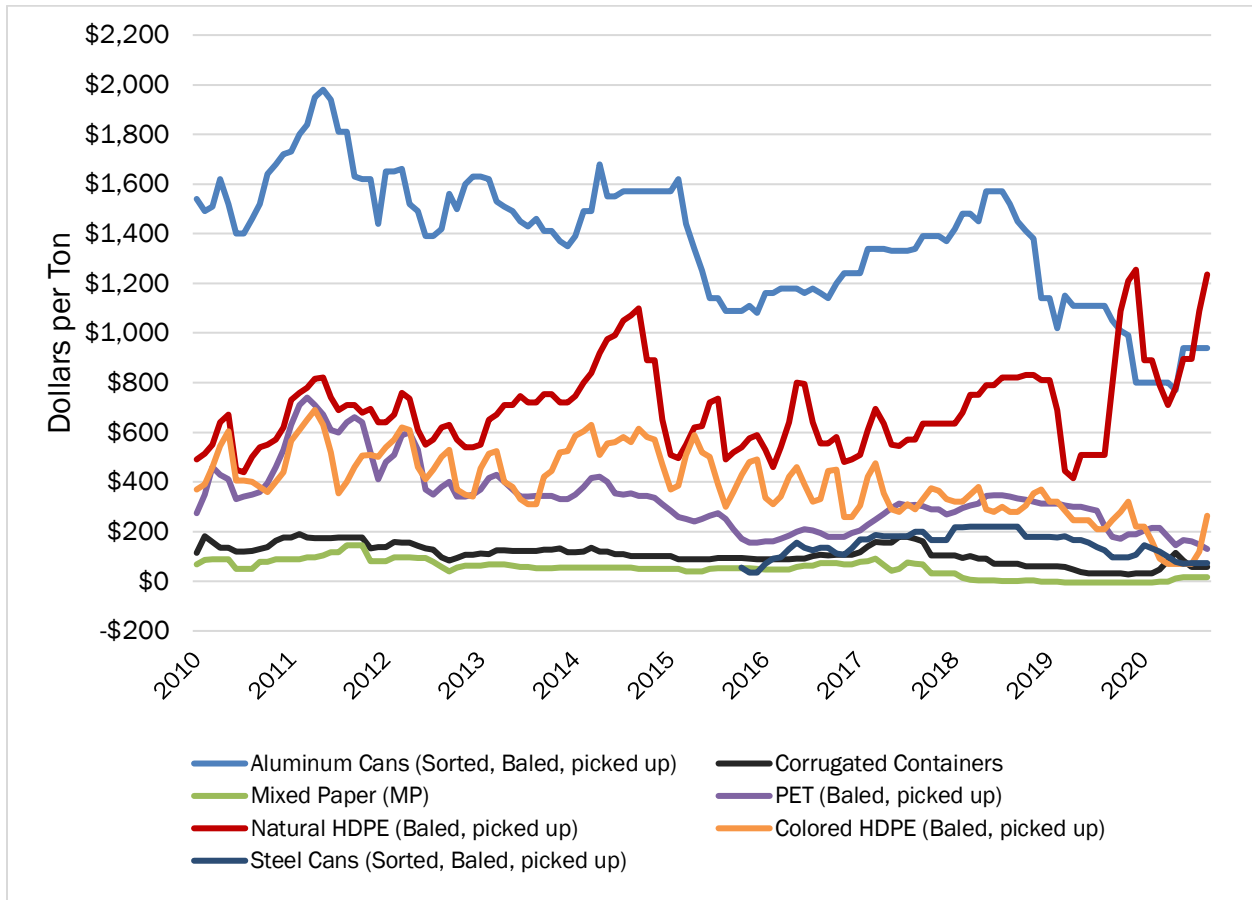

Source: RecyclingMarkets.net

## 2.2.2 CURRENT MARKETS

At the current time, the U.S. recycling industry is in an extended period of subpar financial performance, brought on by a confluence of factors, which include:

- ◆ **Loss of Export Markets:** In 2017, over 37 percent of curbside recyclables were exported to China and other (predominantly Asian) countries for recycling. This changed with the implementation of China’s National Sword Policy in 2017 which shut off imports from the U.S. and the European Union. As Table 2-1 shows, by mid-2020, exports totaled less than 19 percent.

Table 2-1 Recycling Commodity Destinations 2017-2020

Year	Domestic	China
2020	81.5%	2.0%
2019	77.0%	8.0%
2018	68.0%	5.0%
2017	62.9%	27.2%

Source: Waste Expo 2020 “How Recyclers Ride Rough Times” presentation, September 14, 2020



## RECYCLING STANDARDIZATION & RECOVERY

- ◆ **Conversion to Lidded Carts Increases Contamination:** At the outset of single-stream recycling, the shift from 18-gallon bins to 65-gallon carts for recycling setouts was seen entirely in a positive light. The carts provided greater storage volume, so residents were less tempted to discard larger recyclables (cardboard boxes, laundry detergent jugs) that overflowed their bin. Carts prevented precipitation from soaking paper and cardboard. Finally, carts could be collected via fully automated collection trucks, increasing collection efficiency, and improving staffing conditions. While these are indeed benefits, the industry over time found that the incidence of contamination in lidded carts increased significantly. An example of the increases in contamination from a study completed in Florida is shown in Figure 2-2; similar trends are occurring across the U.S.

**Figure 2-2 Recycling Contamination Trends (State of Florida)**

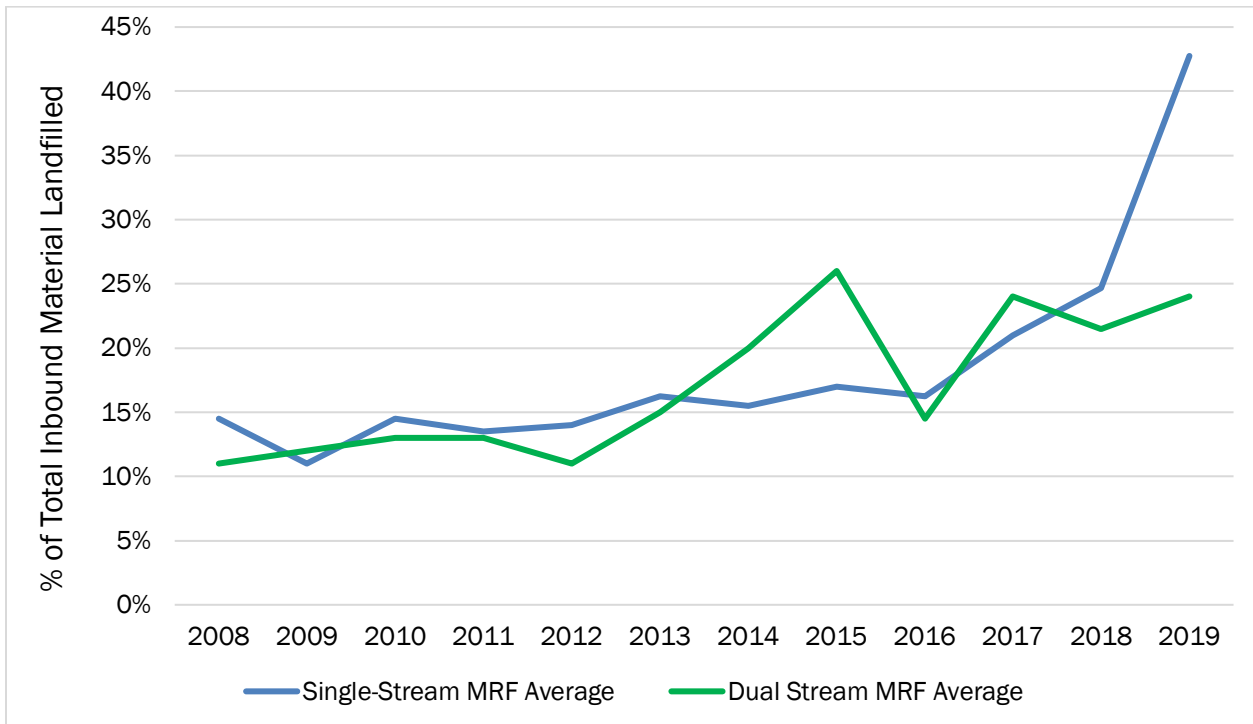

Source: University of Florida “Examining Contamination Rates at Florida Material Recovery Facilities,” March 2020

- ◆ **Diminishing Value of Glass:** Directly related to the rise in single-stream collection is the widespread loss of glass as an economical material for recycling. Single-stream MRFs customarily screen out glass at the front of the processing line along with numerous other non-glass small particles. This process renders the glass both mixed color and very dirty, making it difficult to recycle even if the MRF is willing to pay a downstream market. Due to its weight, glass cannot be economically transported for significant distances. Given that glass makes up roughly 20 percent of the residential recycling stream by weight, the poor economics present unique challenges. Programs that have kept glass source-separated and not included in their single-stream collection have been more successful in marketing cleaner glass for consistent value. Where glass recycling plants are within reasonable distance for transport, drop-off programs are proving beneficial not only for recycling cleaner glass but also leaving the remaining recycling commodities in more marketable condition.
- ◆ **Shortage of Domestic Recycled Paper Mill Capacity:** Related to the 2017 National Sword market disruption which imposed strict limitations on allowable contamination that virtually resulted in cutoff of the outlet for the material, a shortage of domestic mixed paper mill capacity has depressed mixed paper prices. As shown in Figure 2-1, there has been a prolonged low-market value over the past several years for corrugated cardboard and mixed paper. Mixed paper makes up 25 to 30 percent of

# RECYCLING STANDARDIZATION & RECOVERY

---

the residential recycling stream, and cardboard another 20 percent, which only magnifies the impact when this material is in a down market.

- ◆ **COVID-19 Impacts:** Finally, the onset of the COVID pandemic and resulting shutdowns and general behavior change has shifted much waste generation from the commercial back to the residential sector. These impacts have been felt in recycling programs which have seen increases in the amount of recyclables generated, and despite U.S. efforts towards vaccinations, it is not known how prolonged this impact will be. Further, many companies have allowed employees to work from home during the pandemic, and it is not known whether all of those workers will ultimately return to large work centers. If they do not return, that could mean residential recycling and the increased importance of its contribution to the overall recycling stream will remain well beyond the pandemic's end.

## 2.2.3 RECYCLABLES PROCESSING TRENDS

To combat the challenges to processing, MRFs have generally become larger, more capital-intensive, more reliant on automated sorting (including emerging robotics and artificial intelligence, or AI solutions), and therefore more expensive. The increase in the cost to build and operate these MRFs has been driven by higher levels of contamination which have been well documented across the industry. Contamination impairs the mechanical sorting equipment at MRFs, increases the cost of processing, and creates a larger residue stream which is a straight disposal pass-through cost. As a result of these issues, MRFs are more appropriately shifting to a business model that charges suppliers for the cost to process their material as the primary source of revenue, rendering material revenues to be a lesser, though still important, consideration.

Large-scale, modern MRFs typically operate at an all-in cost of \$85 to \$100+ per ton to process recyclables, which is significantly higher than the cost to dispose of materials in a landfill in the Northwest Arkansas region. Finally, privately-owned MRFs have been reluctant to share the true economics of their business models and have leveraged significantly higher revenues from their merchant recycling businesses.

In the past several years, there has been recognition in the private sector that it is not economically viable in many regions to justify a large investment in a traditional MRF. At least one entity is attempting to bring a more economically viable, smaller scale processing solution to market, with an eye towards regions smaller than Northwest Arkansas. It is not certain whether small-scale MRFs will become viable, but all these trends are critical and should be monitored when considering the development of new processing infrastructure in Northwest Arkansas.

## 2.3 RECYCLING COLLECTION PROGRAMS

All the large cities and some small cities in Northwest Arkansas already provide curbside recycling collection to their residents. Some communities and the SWMDs provide recycling drop-off programs. Current residential recycling programs are summarized in the next sections.

### 2.3.1 CURBSIDE COLLECTION

Broadly, there are three technologies for collecting residential curbside recyclables:

- ◆ **Single-Stream:** All cardboard, paper, and metal/glass/plastic bottles and containers are set out for collection in a single recycling cart or bin and collected in a single compartment on the recycling collection truck. Single-stream recycling collection is most often provided via automated collection vehicles.
- ◆ **Dual Stream:** Cardboard and mixed paper are set out in one cart or bin (or bag or bundle), while metal/glass/plastic bottles and containers are placed separately in another bin. These two streams are then collected in two separate compartments on the recycling collection truck.
- ◆ **Curb-Sort:** The oldest form of curbside collection requires the recycling collection crew to manually sort individual commodities into five or more separate compartments on the collection vehicle, essentially segregating each commodity.

## RECYCLING STANDARDIZATION & RECOVERY

Note that these terms are used to denote how many compartments there are on the curbside collection vehicle, and not how many bins or containers are set out by residents. For example, residents in the City of Fayetteville are directed to place all cardboard and paper in one bin, and all containers in another. The set-out could therefore be considered as “dual stream.” However, the recycling collection crew then further sorts the materials from the two bins into six compartments on the collection truck. Therefore, this is considered a Curb-Sort system. Figure 2-3 depicts these three options for curbside collection.

**Figure 2-3 Curbside Recycling Collection Methods**



Single-Stream Automated

Dual Stream

Curb-Sort

Nationally, single-stream recycling programs serve the vast majority of residential households, and the industry is generally converging on single-stream collection as the most viable long-term solution due to higher collection productivity, greater storage volume (i.e., in a cart) for recyclables, and a safer work environment that does not require manual handling of any bins or materials.

There are 37 cities and towns in the tri-county region included in this planning process. Table 2-2 summarizes the service delivery methods for residential recycling, as well as the population served by each. (These collection services may be provided under contract, or by a public collection operation.) As shown, roughly two-thirds of the population is served by curbside collection. However, the population served by single-stream and curb-sort programs are evenly split in the Boston Mountain SWMD, while residents in the Benton County SWMD are predominantly receiving single-stream collection. No dual-stream collection programs exist in the region, and drop-off recycling programs continue to serve a number of residents.

**Table 2-2 Municipal Recycling Collection Program Distribution in Northwest Arkansas**

Collection Type	Boston Mtn. SWMD		Benton Co. SWMD		Total NW Arkansas	
	Communities	Population	Communities	Population	Communities	Population
Single-Stream*	6	94,604	9	156,747	15	251,351
Dual Stream	0	0	0	0	0	0
Curb-sort	2	93,835	1	17,303	3	111,138
Drop-off	6	11,478	5	44,310	11	55,788
Unknown**	2	167	6	6,893	8	7,060
<i>Unincorporated</i>		55,779		48,335		104,114
<b>Total</b>	<b>16</b>	<b>255,863</b>	<b>21</b>	<b>273,588</b>	<b>37</b>	<b>529,451</b>

\*There are portions of Elm Springs and Springdale in both districts

\*\*Unknown could include towns with citizens direct-subscribing with district-licensed haulers

Private haulers also may be providing curbside recycling, although they are primarily offering refuse service. Roughly six private haulers operate in the region that can provide curbside recycling on a subscription basis.

# RECYCLING STANDARDIZATION & RECOVERY

When evaluating the effectiveness of the collection methods used for current curbside programs, it is informative to understand the amount of recyclables being captured by each type. The Recycling Partnership (TRP) has devoted significant research to this question and has published available data on a still-growing database of communities. This is shown in Table 2-3. As shown in this table, cart-based recycling collection programs are capturing a higher weight of household recyclables compared to bin-based or bag-based programs, although they are also associated with higher contamination. This is yet another dynamic that is influencing the industry’s preference for cart-based programs.

**Table 2-3 Average Curbside Recycling Performance (Annual Pounds per Household)**

Residential Recycling Container	Avg. Lbs./HH Collected	Median Lbs./ HH Collected	Number of Community Data Points
Bin	360.4	363.3	48
Bag	324.8	353.7	6
Cart	458.8	452.6	242
Programs Using a Combination of Bins & Carts	451.5	448.8	47

Source: The Recycling Partnership: “2020 State of Curbside Recycling” report

Comparable metrics are available for some of the communities in Northwest Arkansas for which household and tonnage data could be confirmed. These programs are shown in Table 2-4. Although the data are limited, there is higher capture rate of recyclables in single-stream programs, which is consistent with the TRP data. All the programs in the region exhibit below-average recycling capture. While these programs may recycle fewer pounds per resident annually, the curb sort programs have also been proven to produce less-contaminated recyclables.

**Table 2-4 NW Arkansas Curbside Recycling Performance (2018 Pounds Diverted per HH)**

City	HH in Curbside Program	Annual Tons Collected	Lbs. per HH	Program Type
Johnson	827	173	418	Single-Stream in Carts
Bentonville	17,700	2,603	294	Single-Stream in Carts
Fayetteville	23,307	2,844	244	Curb-sort in Bins
Prairie Grove	2,047	233	228	Curb-sort in Multiple Bins, Bags or Boxes
Siloam Springs	5,300	319	120	Curb-sort in Bins

Compiled from multiple sources.

The data in this table support the belief that recycling programs could function more effectively in the region, which would capture a higher volume of targeted materials across all curbside programs. Table 2-5 applies the available data points within the region to estimate current residential curbside recycling tonnage, and compares this to an optimized, standardized system relying on single-stream curbside collection. Optimized diversion is based on the median annual quantity for cart-based recycling programs from Table 2-3. As shown, the region could increase its residential recycling from roughly 15,800 tons per year to almost 28,000. Allowing for growth, optimized residential curbside recycling would be expected to reach 35,000 tons for the combined region by 2030.

## RECYCLING STANDARDIZATION & RECOVERY

**Table 2-5 NW Arkansas Curbside Recycling Performance (2018 Pounds Diverted per HH)**

SWMD	Municipality	Population	Est HH	Status Quo			Optimized	
				Recycling Collection Type	Current Lb/HH	Annual Tons	Optimal Lb/HH	Optimal Tons
<b>Boston Mountain Curbside Programs</b>								
	Elkins	3,151	1,050	Single-stream	294	154	452.6	238
	Elm Springs	2,220	740	Single-stream	294	109	452.6	167
	Farmington	7,110	2,370	Single-stream	294	349	452.6	536
	Fayetteville	87,941	23,307	Curbsort	244	2,844	452.6	5,274
	Johnson	3,790	827	Single-stream	418	173	452.6	187
	Prairie Grove	5,894	2,047	Curbsort	228	233	452.6	463
	Springdale	74,501	24,834	Single-stream	294	3,652	452.6	5,620
	Tontitown	3,832	1,277	Single-stream	294	188	452.6	289
	<b>Subtotal</b>	<b>188,439</b>	<b>56,452</b>			<b>7,702</b>		<b>12,775</b>
<b>Benton County Curbside Programs</b>								
	Bentonville	50,647	17,700	Single-stream	294	2,603	452.6	4,006
	Centerton	14,384	4,795	Single-stream	294	705	452.6	1,085
	Elm Springs	173	58	Single-stream	294	9	452.6	13
	Garfield	588	196	Single-stream	294	29	452.6	44
	Little Flock	2,829	943	Single-stream	294	139	452.6	213
	Lowell	9,467	3,156	Single-stream	294	464	452.6	714
	Rogers	68,248	22,749	Single-stream	294	3,346	452.6	5,148
	Siloam Springs	17,303	5,300	Curbsort	120	319	452.6	1,199
	Springdale*	10,411	3,470	Single-stream	294	510	452.6	785
	<b>Subtotal</b>	<b>174,050</b>	<b>58,367</b>			<b>8,123</b>		<b>13,208</b>
Allowance for Unincorporated Areas and Residential Drop-off								<b>2,000</b>
<b>TOTAL</b>		<b>362,489</b>	<b>114,819</b>			<b>15,825</b>		<b>27,984</b>

\*Springdale data (within Benton County) includes Bethel Heights, which became a part of Springdale in August 2020.

Finally, Table 2-6 estimates the volume of recyclables available in the residential and commercial waste streams in the region, and projects the growth of recoverable fiber and containers through 2030. As shown, almost 80,000 tons of material will be generated, split in roughly equal proportions from residential and commercial generators.

**Table 2-6 Projected Quantity of Fiber and Container Recyclables in Northwest Arkansas**

Sector	District	2018	2020	2025	2030
Residential	Benton	14,510	15,320	17,360	19,590
	Boston Mountain	13,890	14,710	16,860	19,230
	<i>Subtotal</i>	28,400	30,020	34,210	38,820
Commercial	Benton	15,880	16,760	18,990	21,440
	Boston Mountain	13,830	14,640	16,790	19,150
	<i>Subtotal</i>	29,710	31,410	35,780	40,590
<b>Total</b>		<b>58,110</b>	<b>61,430</b>	<b>69,990</b>	<b>79,400</b>



# RECYCLING STANDARDIZATION & RECOVERY

## 2.3.2 DROP-OFF RECYCLING AND CITIZEN CONVENIENCE CENTERS

Drop-off programs provide access to recycling beyond curbside collection and are often effective options to service rural areas. Both Districts provide recycling drop-offs as well as convenience centers which accept a broader spectrum of materials, such as trash, household hazardous waste (HHW), and electronic waste (e-waste). Table 2-7 provides a listing of recycling drop-offs as well as broader convenience centers available in the area. Detailed information about the accepted recyclables, hours of operation, and drop-off facility location is provided by both Districts on their respective websites.

**Table 2-7 Northwest Arkansas Recycling Drop-offs and Citizen Convenience Centers**

Locations	Drop-offs	Trash	HHW	E-Waste
Bella Vista	X			
Bentonville [1]	X			
Boston Mtn. SWD	X	X	X	X
Centerton [2]	X	(Bulky)	X	X
Decatur [1]	X			
Elkins [3]	X			
Fayetteville	X (2)	X		
Gentry [1]	X			
Garfield [1]	X			
Goshen [4]	X			
Gravette [1]	X			
Madison County Solid Waste & Recycling	X	X	X	X
Pea Ridge [1]	X			
Rogers Satellite [2]	X	(Bulky)	X	X
Siloam Springs Satellite [2]	X	(Bulky)	X	X
Siloam Springs Recycling & Transfer Station	X	X		
Springdale [4]	X		X	X
University of AR-Fayetteville	X			
West Fork [4]	X			
Winslow [3]	X			

[1] Benton County SWMD and City Collaboration

[2] Benton County and Benton County SWMD Partnership

[3] Operated by Boston Mountain SWMD

[4] Boston Mountain SWMD and City Partnership

## 2.3.3 COMMERCIAL RECYCLING COLLECTION

Commercial recycling programs in the region at the current time are driven predominantly by the economics of recycling at individual businesses and institutions. For larger commercial and institutional establishments that generate large volumes of recyclable material, it is economical to divert recyclable items which typically result in avoidance of disposal fees. Although some Fortune 500 companies are based in the region, and these companies have stated goals to increase diversion of recoverable materials, there are currently no local, state, or federal regulations, nor are there expected to be any new regulations, that would mandate the separation of recyclables from commercial establishments.

The 2018 Needs Assessments submitted to Arkansas DEQ for both Boston Mountain and Benton County identify haulers who offer commercial recycling collection (which could be provided via either dumpster



# RECYCLING STANDARDIZATION & RECOVERY

or roll-off service). Approximately one dozen collection providers would be capable of collecting recyclables from commercial and institutional entities.

It was beyond the scope of this planning process to inventory the commercial recycling programs in the study area. However, geographically convenient processing infrastructure would be expected to improve recycling economics for the commercial sector by reducing transportation costs and expanding the types of commercial collection programs that could be financially justified.

## 2.4 RECYCLING ECONOMICS

### 2.4.1 RESIDENTIAL RECYCLING PROGRAMS

A critical component to successful residential recycling is the ability to recover sufficient revenues from residential households to fund the system. While it was beyond the ability of this planning process to compile the specific funding and revenue strategies for every recycling program in the region, there are three primary ways residential recycling is currently funded:

- ◆ **User Fee Funding:** The large cities and many of the small cities in the region operate their solid waste services like any utility and have established user fees for all curbside waste and recycling collection services. User fee-funded systems charge households (and businesses, if served) a monthly or quarterly rate to cover the cost of trash, recycling, yard waste and bulky waste collection, processing, and disposal. User fees are primarily charged through the city, but in some communities in Northwest Arkansas, residents pay their fees directly to a contracted hauler.
- ◆ **General Funding:** Some cities may simply cover waste management and recycling costs through their general taxes, or else the Districts provide recycling services through their funding external to the cities. This is the case for smaller communities that offer only drop-off recycling.
- ◆ **Subscription Service:** Households that wish to have curbside recycling but cannot obtain this as a standard service through their city, can subscribe with a private hauler for curbside recycling. Subscription recycling collection usually has the highest cost, and consequently is not widespread.

Regardless of how curbside (or drop-off) recycling is funded, all the cities in the region will have a strong interest at minimizing cost or rate increases over a short time period. Recycling collection and processing makes up a relatively small portion of the overall trash bill. However, investing in a regional processing center or upgrading to new collection technologies will increase the cost for every community.

It will be critical for the region to recognize the importance of the challenges and opportunities to modify current funding levels and methods to sustain a regional recycling program. Elected officials are generally hesitant to allow significant increases to user fees or taxes, which means that any regional recycling solution must be integrated into current budgets in such a way as to limit rate shocks.

### 2.4.2 CONTRACTUAL ARRANGEMENTS

Another critical consideration for advancing recycling in the region is the need to navigate numerous contractual obligations among local governments and waste and recycling service providers. Figure 2-4 summarizes existing contracts (as of early 2020 when the data was gathered) that could influence the speed and timing of any migration to a more regionally coordinated materials management system. Municipalities with expiring contracts will need to balance contract extensions and re-bids with the timing of regional recycling system development.

# RECYCLING STANDARDIZATION & RECOVERY

Figure 2-4 Recycling Collection and Processing Contract Expirations and Optional Extensions

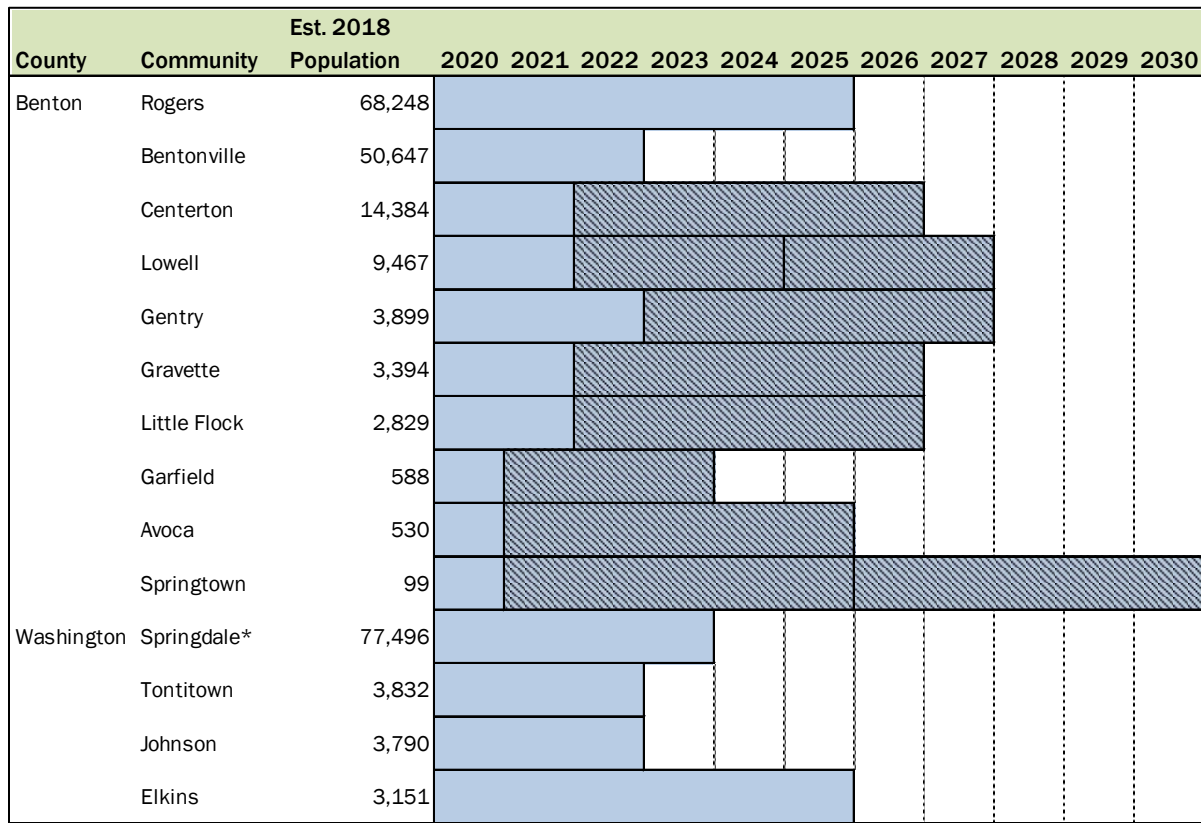

### 2.4.3 MARKETS IN AND AROUND NORTHWEST ARKANSAS

It is helpful to understand the value of recyclables being collected from the residential sector in Northwest Arkansas. This is shown in the following tables. Table 2-8 shows the current value of a typical basket of curbside recyclables originating from a generic<sup>2</sup> single-stream collection program. It should be noted that some of the commodities, such as Aseptics & Cartons, #3-7 Plastics, and Mixed Rigid Plastics, are not commonly collected in northwest Arkansas, and glass is predominantly collected in source-separated drop-offs.

<sup>2</sup> It was reported by a third party that the contamination level at Marck Industries recycling facility is closer to 29 percent. This estimate was not corroborated by the Project Team, and the table in this section does not attempt to estimate the actual composition at the Marck facility.

## RECYCLING STANDARDIZATION & RECOVERY

**Table 2-8 Blended Market Value for Generic Single-Stream Mix**

Commodity	Composition of Recyclables	Market Value (\$/ton)	Blended Value per Ton
Cardboard	18.1%	\$55.00	\$9.94
Mixed Paper	34.8%	\$27.50	\$9.56
Aseptics & Cartons	0.1%	N/A	N/A
Aluminum Cans	1.2%	\$950.00	\$11.45
Steel Cans	1.7%	\$95.00	\$1.59
Glass	17.4%	(\$25.00)	(\$4.36)
PET	3.6%	\$140.00	\$5.06
HDPE Natural	0.8%	\$1,245.00	\$10.39
HDPE Colored	0.9%	\$265.00	\$2.46
#3-7 Plastics	1.0%	(\$20.00)	(\$0.20)
Mixed Rigid Plastics	0.4%	\$50.00	\$0.19
Residue	20.0%	(\$40.00)	(\$8.00)
<b>Total</b>	<b>100.0%</b>		<b>\$38.06</b>

Sources: Percentages estimated by MSW Consultants; market values provided by RecyclingMarkets.net for Sept. 2020

Table 2-9 reflects the value of the same recyclables but from a manually collected, curb-sorted program. Curb-sort recyclables tend to have less contamination, but also a lower volume of cardboard and lower volumes overall. Based on current market pricing, the value per ton of curb-sort material is significantly higher due to the avoidance of the higher rate of contamination seen in single-stream systems. However, as shown previously in Table 2-3, less material per household is recovered from curb-sort programs in the region.

**Table 2-9 Blended Market Value for a Generic Curb-sort Mix**

Commodity	Composition of Recyclables	Market Value (\$/ton)	Blended Value per Ton
Cardboard	12.6%	\$55.00	\$6.93
Mixed Paper	49.0%	\$27.50	\$13.47
Aluminum Cans	1.7%	\$950.00	\$16.13
Steel Cans	2.4%	\$95.00	\$2.23
Glass	24.6%	(\$25.00)	(\$6.14)
PET	5.1%	\$140.00	\$7.13
HDPE Natural	1.2%	\$1,245.00	\$14.64
HDPE Colored	1.3%	\$265.00	\$3.46
Residue	2.3%	(\$40.00)	(\$0.90)
<b>Total</b>	<b>100.0%</b>		<b>\$56.95</b>

Sources: Percentages estimated by MSW Consultants; market values provided by RecyclingMarkets.net for Sept. 2020

These differences in the value of recyclables are particularly important in Northwest Arkansas, where both single-stream and curb-sort collection programs are in operation. As shown, the value per-ton of curb-sort material tends to be meaningfully higher than single-stream due to cleanliness; however, the volume of material in curb-sort programs is usually much lower and may not capture as much cardboard and large

# RECYCLING STANDARDIZATION & RECOVERY

format plastic bottles (i.e., large laundry detergent bottles) due to lack of storage space in the smaller recycling bins.

Materials in the Midwest have been fortunate to have more domestic outlets than many processors in coastal regions. Although it was not investigated extensively as part of this study, the TSC’s evaluation of the circular economy in Northwest Arkansas notes that the closest large-scale glass market is in Kansas City, and that regional markets for plastics could be expanded. For other commodities, the regional market is believed to be reasonably robust and able to absorb clean recyclables.

## 2.5 CURRENT PROCESSING FACILITIES

There are multiple facilities in the Northwest Arkansas region which accept recyclables for bulking and baling or otherwise shipping directly to market. Such facilities are operated by the Districts, cities, and the University of Arkansas, and were highlighted in Table 2-7.

Within the region there is one facility that accepts mixed recyclables and processes the recyclables to sort and bale recoverable commodities. Marck Industries, located in the city of Rogers, receives residential recyclables collected throughout the region, some material from outside of the region, and commercial recyclables. The facility estimated that single-stream curbside material comprised approximately 30 percent of its feedstock.

Figure 2-5 shows the location of the Marck Industries MRF (as well as other solid waste facilities in and around the region). The Marck Industries recycling facility is located several miles from Interstate 49 and is not as geographically convenient to cities in Madison County, Washington County, and western Benton County.

Figure 2-5 Facilities within 100 Miles of Tri-County Centroid

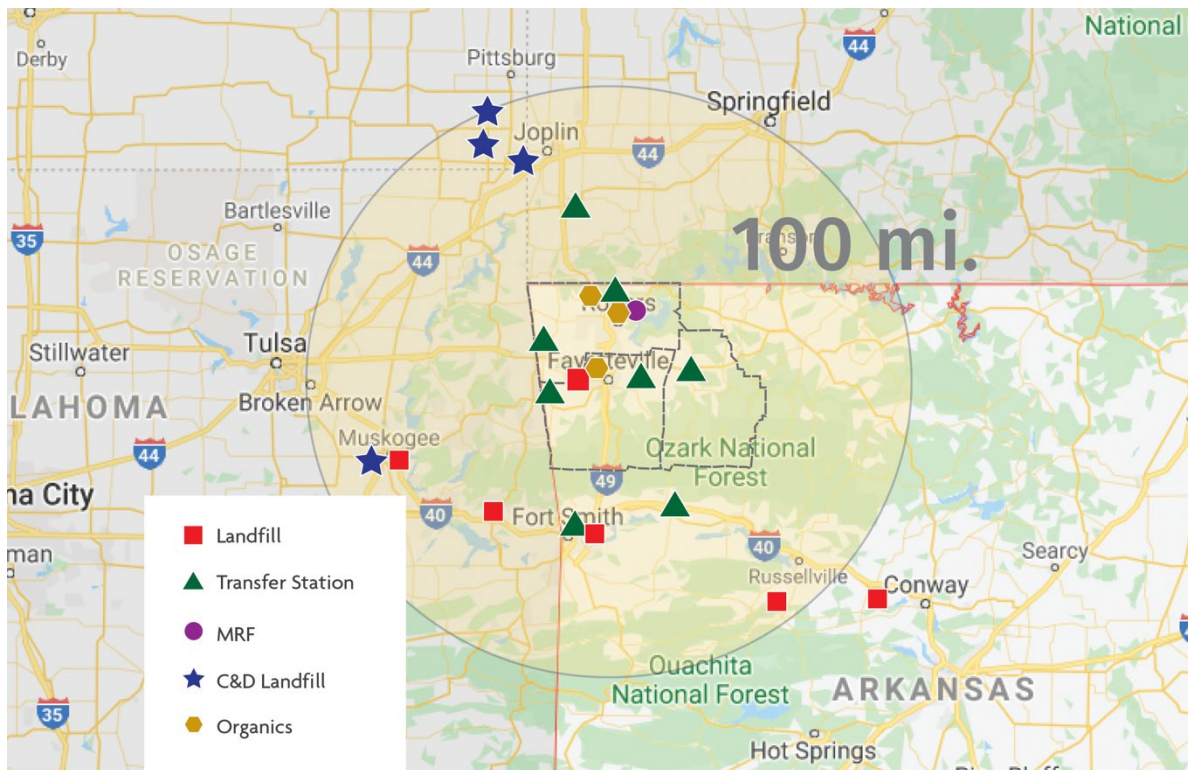

Figure 2-6 shows photos from a site visit to Marck Industries during the stakeholder meeting phase of the project. This facility was found to currently handle recyclables on an as-needed basis and through contracts



# RECYCLING STANDARDIZATION & RECOVERY

with private haulers, using an older hand-sort model of sorting with basic magnets assisting for metals. There is some additional capacity open for use by local agencies to supply material.

**Figure 2-6 Marck Industries Recycling Facility**



Outdoor Bunker

Infeed

Loading Bays

Based on interviews with facility operations management, Marck leadership confirmed that they are aware of the need to increase processing capacity in the region and that they are poised to invest in this facility as opportunities arise. It was further reported that there may be grants available to help fund an update to a more automated processing configuration in 2021. Marck Industries is interested in continued participation in expanding recycling within the study region and would be expected to pursue such expansion opportunities.

It should be noted that current processing fees, revenue share, or other terms for delivering recyclables to the Marck facility are negotiated between Marck and various private haulers rather than directly with the communities the recyclables come from. The terms of these agreements were reported to be confidential and were not available. This is because most residential single-stream recyclables collection is performed under contract with the cities, and the contracted haulers arrange for processing directly with Marck Industries. Table 2-10 shows 2019 reported processing fees based on a large-scale survey of communities with direct processing contracts. At the time of this research, processing fees clustered in the range of \$70 per ton. However, developments in 2020 have been reported to have increased processing fees in many regions of the U.S., in some cases substantially.

**Table 2-10 Regional MRF Processing Fees (2019)**

EPA Region	States	Average Fees	Median Fees	Communities Reporting
4	Kentucky, Tennessee, Mississippi, Alabama, Georgia, South Carolina, North Carolina, Florida	\$70.75	\$77.64	31
6	Arkansas, Louisiana, Texas, Oklahoma, New Mexico	\$72.39	\$77.51	16
7	Missouri, Kansas, Nebraska, Iowa	\$68.36	\$65.00	7

Source: The Recycling Partnership: “2020 State of Curbside Recycling” report.

## 2.6 VISION FOR A REGIONAL RECYCLING SYSTEM

Based on input from stakeholders, there is strong interest in evolving the region to develop a consistently branded, high-performing, cost-effective recycling system. This section discusses the following key elements to such a system:

# RECYCLING STANDARDIZATION & RECOVERY

- ◆ Standardization of Recycling Materials and Outreach,
- ◆ Migration to a Standard Curbside Collection System,
- ◆ Development of Regional Recyclables Processing Infrastructure, and
- ◆ Management of the Regional System.

## 2.6.1 STANDARDIZATION OF RECYCLING MATERIALS AND OUTREACH

At the current time, every city and the Districts have their own websites, brands, and even targeted material lists that can be influenced by contracts with private haulers or residential or commercial subscriptions. Extensive information about recycling is available in some communities, while others have little information available about their recycling programs. Focus groups conducted by the Northwest Arkansas Council in 2018 identified mixed messaging and an awareness among focus group participants that recycling programs were inconsistent between home and work within the region.

In the move to a regional recycling system, it will be necessary to standardize the way in which residents and businesses perceive and interact with recycling programs. A regional program would be expected to offer:

- ◆ **Branding:** The regional recycling program would benefit from a recognizable logo, catch-phrase, and other messaging.
- ◆ **Uniformly Targeted Recyclables:** In order to accommodate the different targeted materials that exist now, it may be necessary to develop a primary (universal) list and secondary (optional) list of recyclables. The universal materials would be collected in every community in the region and would be featured prominently, while the optional materials would be supplemental and could be captured at a local convenience center. A basic and expanded materials list for recycling through the region is provided in Table 2-11.

**Table 2-11 Basic and Expanded Standardized Recyclables Material List**

Material Group	Universally Targeted	Optional: Check with your Municipality
Residential Paper	◆ OCC	
	◆ Newspaper	
	◆ Junk Mail	◆ Aseptic Containers
	◆ Paperboard	◆ Gable Top Cartons
	◆ Office Paper	
Metal	◆ Aluminum Cans	◆ Aluminum Tins and Foil
	◆ Steel Food Cans	◆ Aerosol Cans
		◆ Scrap Metal
Glass	◆ Clear Glass Bottles	◆ Check for mixing (curbside) or color-separated (drop-off)
	◆ Green Glass Bottles	
	◆ Brown Glass Bottles	
Plastic	◆ #1 PET Bottles	◆ #2 HDPE Tubs/Lids
	◆ #2 HDPE Bottles	◆ #3-7 Bottles and Containers
		◆ #5 Polypropylene
Other Materials	◆ N/A	◆ List

# RECYCLING STANDARDIZATION & RECOVERY

- ◆ **Widely Available Educational Materials and Coordinated Campaigns:** A central repository with standardized educational materials and programs would further the regional system.

Establishment of these regional standards, as well as determination of a governing or other supervisory entity, is discussed later in this section.

## 2.6.2 MIGRATION TO STANDARDIZED CURBSIDE COLLECTION SERVICE

Residents moving between the Boston Mountain and Benton County SWDs may experience stark differences in recycling collection. Conceptually, a move to standardize curbside recycling collection service to every household in the region makes intuitive sense. However, given the different collection systems in NWA, a subset of municipalities will need to change their collection services to achieve a regional standard.

Table 2-12 attempts to compare and contrast the four recycling collection program types, three of which (drop-off, curbside sort, and curbside single-stream) are in place in Northwest Arkansas.

**Table 2-12 Pros and Cons of Recycling Collection Options**

Collection Method	Pros	Cons
<b>Drop-off</b>	<ul style="list-style-type: none"> <li>• Lowest total cost per household</li> <li>• Used by more committed recyclers, leading to clean material</li> <li>• Can be used by small businesses that otherwise might not recycle</li> <li>• If source-separated, can ship materials directly to market</li> </ul>	<ul style="list-style-type: none"> <li>• Lowest recovery per household</li> <li>• Less convenient than curbside</li> <li>• Limited flexibility to modify the accepted materials or change the mix of recovered materials</li> <li>• Does not follow utility operating or rate setting model</li> </ul>
<b>Curb-sort</b>	<ul style="list-style-type: none"> <li>• Direct feedback on recycling accuracy can be provided to participating households</li> <li>• Generates very clean materials</li> <li>• Lowest processing cost per ton of curbside programs due to avoidance of sorting</li> <li>• Can ship many commodities direct to market</li> <li>• Low capital cost of collection vehicles</li> <li>• Firmly established in NWA</li> </ul>	<ul style="list-style-type: none"> <li>• Lowest collection productivity (households served per hour) of any curbside recycling method</li> <li>• Highest collection cost per household</li> <li>• Limited storage in bins leads to lower diversion rate compared to carts</li> <li>• Open top bins subject to soaking due to precipitation</li> <li>• High impact (injury, turnover) on collection crew from manual collection requirement</li> </ul>
<b>Curbside Dual Stream</b>	<ul style="list-style-type: none"> <li>• Increased collection productivity over curb-sort</li> <li>• Can introduce carts for one or both streams, increasing capacity for recovery</li> <li>• Increased diversion compared to curb-sort especially if one stream is carted</li> <li>• Generates cleaner materials compared to single-stream</li> </ul>	<ul style="list-style-type: none"> <li>• Increases potential for contamination to rise</li> <li>• Open top bins subject to soaking due to precipitation</li> <li>• Difficult for communities with single-stream to reduce convenience to customer and go back to dual stream</li> <li>• Requires specialized processing to sort out contamination and separate recyclable commodities</li> <li>• High impact (injury, turnover) on collection crew from manual collection requirement</li> </ul>

# RECYCLING STANDARDIZATION & RECOVERY

Collection Method	Pros	Cons
<b>Curbside Single-stream</b>	<ul style="list-style-type: none"> <li>• Highest collection productivity of any curbside recycling system</li> <li>• High convenience to residents (so separating, one convenient storage container)</li> <li>• Highest diversion rate</li> <li>• Fully automated collection creates safest work environment of any curbside collection method</li> <li>• Already widely adopted in NWA</li> </ul>	<ul style="list-style-type: none"> <li>• Eliminates ability to easily monitor and correct improper set-out behavior</li> <li>• More susceptible to high contamination</li> <li>• Requires specialized processing to sort out contamination and separate recyclable commodities</li> <li>• Most expensive processing cost</li> <li>• Greater yield loss for recyclable paper due to glass and other cross contamination</li> <li>• Most expensive and mechanically complex collection vehicles</li> <li>• Requires capital investment in carts for every household</li> </ul>

Migrating from one collection technology to another requires extensive planning combined with the political willpower to change. Recent attempts by the City of Fayetteville to migrate from curb-sort to single-stream recycling was rife with controversy and it is unlikely Fayetteville will consider another form of recycling collection in the foreseeable future. Based on the history of curbside recycling programs, Fayetteville and other cities with curb-sort recycling could potentially evolve from a curb-sort to a dual-stream program as an intermediate solution, before deciding if full single-stream collection is appropriate. The same dynamic likely exists in other communities.

Conversely, communities that currently have single-stream collection cited wide popularity with the program and would be unlikely to go back to recycling programs that require additional storage containers and a greater degree of sorting required of the resident. Convenience, once offered, is difficult to take away.

The path toward any true regional recycling program must therefore be flexible enough so that every incorporated municipality can participate in the regional system from day one but enable municipalities to evolve their collection services over time. It should be noted that other regions of the country have successfully established regional processing solutions that accommodate different collection methods, and information available to the Project Team suggests that Marck Industries already does this regionally insofar as they are accepting only some single stream materials, with the rest being source separated to a greater degree.

## 2.6.3 DEVELOPMENT OF REGIONAL RECYCLABLES PROCESSING INFRASTRUCTURE

As a final, and critical, component of a regional recycling system, consideration should be given to the development of processing infrastructure that is centrally located, accessible, and has sufficient capacity to both serve the current regional recycling needs and also grow with the region. There are many considerations to be made in developing regional processing infrastructure:

- ◆ **Dual-Stream or Single-stream Processing Capabilities?** Modern MRFs are typically designed to meet the processing needs of the region. Regions with dual-stream recycling collection have historically developed MRFs that assume two inbound material streams, one each for fiber and commingled containers. Single-stream MRFs generally assume that all fiber and containers will be mixed together. In some regions, dual stream material is processed by single-stream MRFs, but the result is a degradation of the dual stream material at a higher than necessary processing cost. NWA



## RECYCLING STANDARDIZATION & RECOVERY

stakeholders will need to carefully consider the most appropriate processing technology to best serve the region.

- ◆ **One Large MRF or More Than One Smaller MRFs?** Similarly, there is a balance between convenience and economics. Recyclables processing efficiency is influenced by scale; larger facilities can achieve the lowest processing cost per ton. However, two facilities (or more) could potentially provide either greater convenience (i.e., avoidance of transportation cost and lost collection productivity) or potentially provide multiple processing technologies (e.g., one single-stream and one dual-stream MRF) to serve the region.
- ◆ **Size the MRF for Residential Materials Only, or Size for Residential and Commercial?** A potentially major consideration will be whether to design recycling capacity for the entire residential and commercial sector, or to focus only (or predominantly) on the residential sector. This decision will have major decisions on facility sizing. If commercially generated recyclables could be captured, it would be possible to build a larger facility with lower unit costs. However, the generation and collection of commercial recyclables takes place between private generators and private haulers who are not beholden to use a publicly-funded regional MRF.<sup>3</sup> A safer proposition is to design a regional facility to serve the residential sector, and establish supply agreements with the municipalities and the Districts to serve as an outlet for their recyclables.

Given these variables, a range of regional processing options were considered for evaluation by the region’s stakeholders. These options are listed in Table 2-13.

**Table 2-13 Regional Recyclables Processing Options**

Option	No. of MRFs	Processing Technology	Design Capacity for...	
			Residential Recyclables	Commercial Recyclables
1	Two (one per District)	Single-Stream	✓	
2	Two (one per District)	Dual-Stream	✓	
3	One Regional MRF	Single-Stream	✓	
4	One Regional MRF	Dual-Stream	✓	
5	One Regional MRF	Single-Stream	✓	✓
6	One Regional MRF	Dual-Stream	✓	✓
7	One Regional MRF	Multi-Stream	✓	✓

The final option in this table refers to a “multi-stream” facility. A multi-stream facility is one in which single-stream, dual stream, or curb-sort material could all be delivered with the ability to receive the material in segregated tip floors and to minimize extraneous processing (for example, forcing dual stream material to proceed up the single-stream infeed). Many single-stream facilities allow some source separated material, especially cardboard, to be delivered separately and recovered without processing through the full single stream infeed.

Figure 2-7 depicts a basic schematic of a multi-stream MRF. As shown, there are tipping floors for single-stream, dual stream, and curb-sort material. The multi-stream MRF requires a larger footprint, and may have some redundancy in equipment (e.g., infeed conveyors) compared to a MRF designed to accept only

<sup>3</sup> Theoretically, it may be possible to enact a flow-control measure to compel commercially generated recyclables to be delivered to a regional, publicly-owned MRF. The U.S. Supreme Court has ruled that flow control by ordinance is acceptable under certain conditions for the management of municipal solid waste destined for disposal. Attempts to apply this ruling to regional recycling in Northwest Arkansas would be likely to generate both political controversy and legal challenge. It was beyond the scope of this planning process to consider flow control to manage the regional recycling system.

# RECYCLING STANDARDIZATION & RECOVERY

one mix of recyclables. The “multi-stream” MRF concept is offered for consideration in a region that may have multiple recycling collection methods for the next five or more years.

Figure 2-7 Conceptual Multi-Stream Processing Facility Schematic

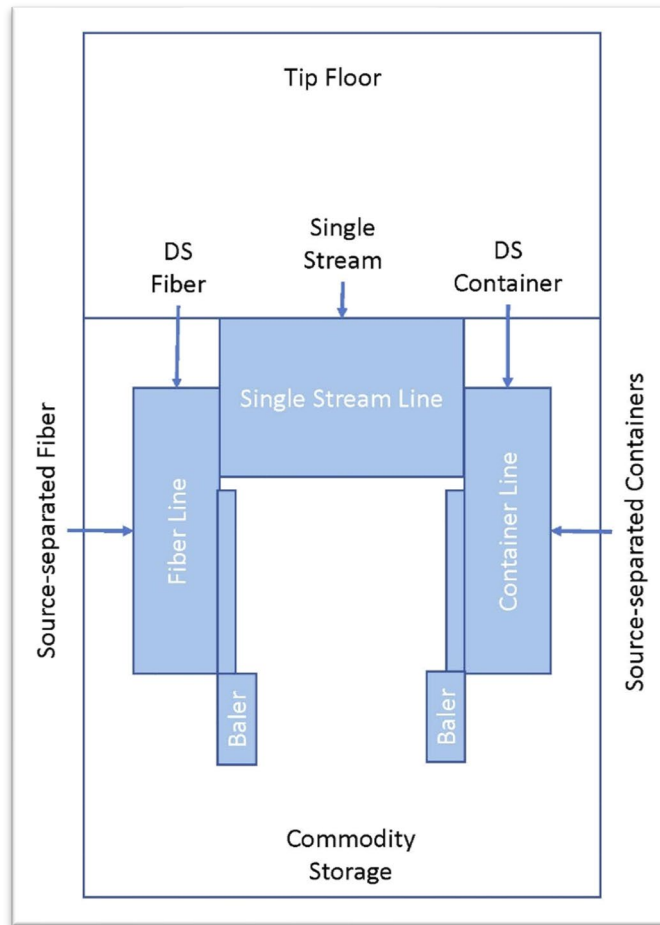

Exhibit 2-1 included at the end of this chapter compares the acreage, total throughput, capital cost, annual operating cost, and processing cost per ton of these seven options. The estimates are based on design capacities and an expectation of working 1.5 shifts per day and five workdays per week and are believed to be reasonable by the Project Team. Land acquisition costs are not included in the capital cost estimate. As shown in the Exhibit:

- ◆ Dual-stream MRFs are less expensive than single-stream MRFs,
- ◆ MRFs with higher throughput are less expensive than MRFs with lower throughput,
- ◆ A large regional MRF is more economical than two (or more) smaller MRFs, and
- ◆ A multi-stream MRF increases the cost despite providing greater flexibility for curbside sort and dual-stream materials to be processed in a way that maximizes the value and recovery rate of the recyclables.

## 2.6.4 OTHER PROCESSING OPTIONS

It should be noted that there are other options to developing processing capacity in the region. These are discussed briefly as one (or more) of these would likely serve if no regional solution is achieved.

- ◆ **Status Quo:** Absent a regional approach, each municipality and the SWMDs will be left to secure recyclables processing individually. Some could build mini-MRFs, but these often apply more manual technology and have not yet been widely established (see below). While the private sector will generally

## RECYCLING STANDARDIZATION & RECOVERY

---

continue to collect and dispose or process materials as needed by the cities, material flows will be harder to track and system costs would be expected to increase faster. Further, if processing is left to the private sector and the terms of processing are not available through the contracting process, cities in the region will have little recourse should the private service providers impose changes or higher fees to processing.

- ◆ **Transfer and Transport to Distant Processing:** As an alternative to developing a regional facility, it may be possible to secure processing capacity in a distant market. However, long-term contracting with any established MRF elsewhere still would require some form of regional cooperation, would incur unknown transportation costs, and further degrade system economics, and recycled materials likely would experience degradation with the additional transfer and tipping.
- ◆ **Mini-MRFs:** Although the MRF industry has seen single-stream facilities increase in size and throughput, a recent entrant has come into the market seeking to bring single-stream processing to smaller communities, often in more rural areas where large-scale facilities could not be justified. These so-called mini-MRFs target smaller communities generating 12,000 tons per year or less. In particular, Closed Loop Partners (CLP), a private investment fund that seeks to expand materials recovery and circular economy supply chains across the U.S., has been attempting to bring to market the Revolution System. This technology provider is currently operating its system in the Town of Steamboat Springs, Colorado, and is developing a similar facility in Cumberland County, New Jersey, which is slated to come on-line in mid-2021.<sup>4</sup> These mini-MRFs are reported by CLP to require 15,000 square feet of space and incur less than \$1.5 million in equipment costs (excluding the building), with an all-in cost in the range of \$70 to \$80 per ton. Figure 2-8 shows a schematic of the Revolution system. This system is more reliant on manual sorting than current large-scale single stream MRFs and has not been commercially established yet. However, CLP offers to accept and market the materials recovered for this system, which reduces the level of effort associated with finding markets. The next several years may better inform if this or any other new mini-MRF technologies establish a successful track record.

---

<sup>4</sup> Neither member of the Project Team endorses any provider of recyclables processing equipment or services. This vendor is identified, however, because they are specifically targeting smaller markets such as several of the cities in Northwest Arkansas, and this solution could warrant additional evaluation if a larger scale regional MRFs does not come to fruition.

# RECYCLING STANDARDIZATION & RECOVERY

Figure 2-8 Mini MRF Schematic for the Revolution System

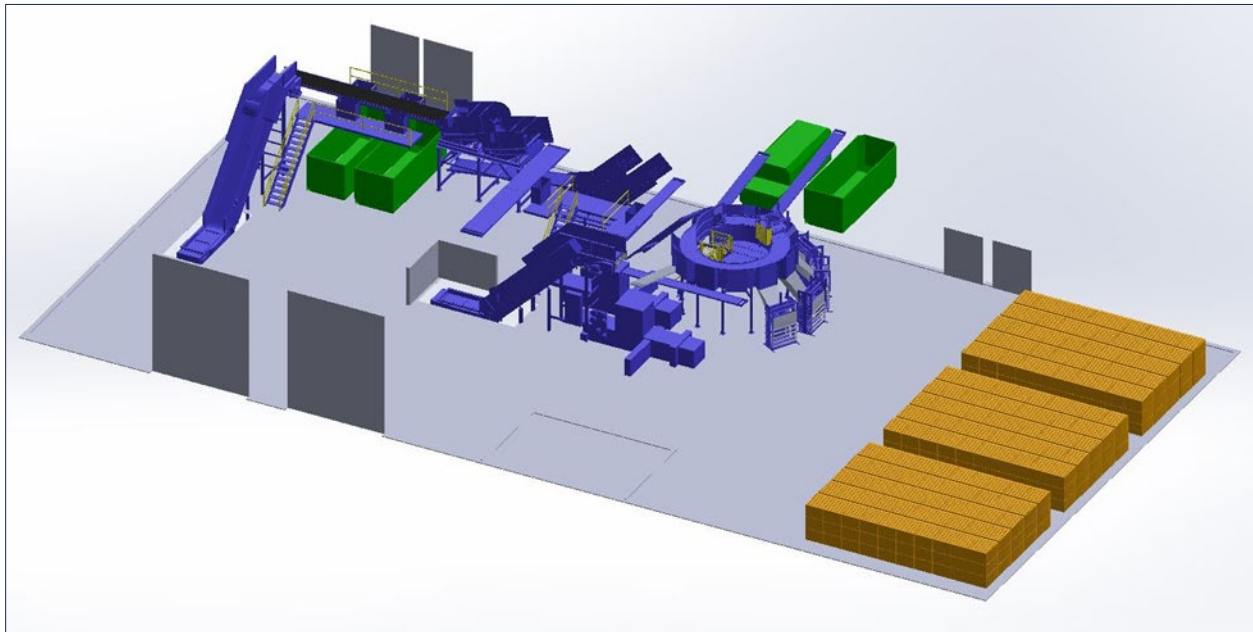

## 2.7 GOVERNANCE OF A REGIONAL RECYCLING SYSTEM

### 2.7.1 MANAGEMENT AND FUNDING

The management of recycling programs and services in NWA has historically been divided among multiple entities.

- ◆ Incorporated municipalities have several revenue mechanisms available to support recycling, most notably user fees and taxes. The full suite of curbside collection services – trash, recycling, yard waste, bulk waste – are considered critical local government services and operate effectively in a utility model. Mayors and elected officials will necessarily be held responsible for evolving successful programs and managing system costs.
- ◆ SWDs have dedicated funding from several sources, including a per capita fee, a waste assessment fee, hauler licensing fees, various service fees from the use of district facilities, and revenue from sale of recyclable commodities deposited at drop-off sites. The districts are already providers of recycling program support, event recycling, and consulting to assist businesses, schools and the incorporated municipalities with their waste management needs. The districts are well positioned to expand their roles to benefit regional recycling and sustainable materials management in general. Opportunities for the districts are shown in the text box below. It will be necessary for the region to determine how best to empower and fund the districts to meet these needs.

# RECYCLING STANDARDIZATION & RECOVERY

## Potential Expanded Roles for SWMDs (or a Regional Waste Management Authority)

- ◆ Coordinate and support overarching regionalization goals
- ◆ Provide procurement Technical Assistance to incorporated municipalities, institutions, and businesses in the region
- ◆ Develop RFP and contract templates for solid waste services that apply best practices and for collection and processing contracts for use by municipalities (or even multi-municipal combinations)
- ◆ Monitor collection and processing contracts for all municipalities to track critical details needed to maintain a competitive and transparent market
- ◆ Establish a more formal procedure for reviewing and signing off on municipal contracts before final execution by the municipality or institutional entity
- ◆ Provide contamination monitoring services for communities with curbside recycling programs
- ◆ Perform routine contamination audits for all suppliers of recyclables to any regional MRF

A true regional system could arguably require the establishment of a single recycling authority with representation from both Districts and from local governments. One alternative would be to combine the two Districts into a single District, although this may require approval from the state. The optimal development of either a single regional manager, or else the development of appropriate interlocal and inter-district agreements, will be an important step toward an optimized regional recycling system.

### 2.7.2 CONTRACTING

The NWA region has a strong reliance on contracts between cities and the private haulers and solid waste facility owners that serve the region. While it is common for local governments to contract for waste and recycling collection, processing and disposal services, the existence of so many contracts creates a level of complexity when attempting to develop regional standards for recycling (or any other aspect of the waste management system).

Migration to a more coherent regional recycling system would benefit from central management of the contractual arrangements throughout the region. The districts (or a regional authority) could be granted some level of input on the contracting process. At a minimum, the districts or a regional authority could provide technical assistance and maintain model RFPs and contracts but leave it up to the cities to invite participation. At the other end of the spectrum, the districts could be charged with responsibility to review and/or approve RFPs and contracts at some point in the cycle. These stages are summarized in Table 2-14.

# RECYCLING STANDARDIZATION & RECOVERY

Table 2-14 Options for Central Management for Municipal Contracts

Option	District's Relationship to Cities	Cost & expertise needed
Maintain a repository of model RFPs and contracts	Consultant	Low
Provide technical advisory services for procurement and contracting	Consultant	Medium
Monitor municipal contracts to support overarching regionalization goals	Consultant	Medium
Perform mandatory review of municipal RFPs and contracts	Partner	High
Mandatory sign-off of municipal RFPs and contracts	Partner	High

The precise role of the districts or a regional authority will need to be determined for the regional recycling system.

### 2.7.3 FACILITY OWNERSHIP

If the region opts to move forward with the development of a regional MRF, it will be necessary to determine details about ownership, project development, and operational management of the facility. Broadly, the options include:

- ◆ **Public Ownership and Operation:** A regional facility could be undertaken solely by the public sector.
- ◆ **Private Ownership and Operation:** Conversely, a regional facility could be entirely owned and operated by the private sector. Marck Industries is the region's sole privatized MRF currently.
- ◆ **Public Ownership and Private Operation:** A hybrid approach that has been used successfully for MRFs in other regions is for the public sector to own the facility and contract operations to an experienced private sector operator. This arrangement is often called a Public-Private Partnership (PPP).

Regardless of the facility ownership, successful operation of a facility will require tonnage commitments and numerous other terms to enable the facility operator to make sound business decisions. No current political system or entity is in place that could manage or has been identified to manage regional solid waste infrastructure. The region should expect to address the issue of regional facility ownership as part of the future regional optimization process.

## 2.8 OTHER RECYCLING STANDARDIZATION RECOMMENDATIONS

The following additional recommendations specific to the regional recycling system will support the migration to a regional solution:

- ◆ **Financial Planning:** Cities and the districts should plan on making use of their revenue mechanisms to generate at least some surplus reserves that could be used to invest in a regional system. Solid waste rate setting should take these investments into consideration. Current solid waste rates may need to undergo routine annual increases in advance of any major regional commitments.
- ◆ **Engage Marck Industries:** Given that there is a processor in the region already, with a stated interest in expanding its ability to accept additional recyclables generated in the region, the Districts should engage Marck Industries in its discussions throughout the process. Under the right terms and circumstances, there is no reason Marck Industries could not expand to serve a larger regional footprint to accommodate more mixed recyclables from residential and commercial generators.

## RECYCLING STANDARDIZATION & RECOVERY

---

- ◆ **Consistent, Ongoing Contamination Management:** Recycling programs primarily exist to provide a clean feedstock to specialized manufacturing facilities. Managing and minimizing contamination is critical. To support any regional recycling program, it is an emerging best practice to periodically audit materials to verify high performance of the recycling system. Two mechanisms to support improvements in recycling contamination are:
  - ◆ **Periodic recycled material composition audits from inbound loads at the MRF.** At a minimum, having an accurate measurement of the composition of inbound single stream materials is critical for a fair and transparent processing contract. Routine composition audits can be used to update the contract payment terms, identify changes in the recycled materials, and monitor the level of contamination being received in the recycling stream.
  - ◆ **Recycling container monitoring.** Conducting curbside cart or bin inspections and tagging the recycling containers with feedback to citizens over a period of three or four consecutive weeks has become a common approach across the country. Funding is being provided from internal city funds, regional grants, and through The Recycling Partnership, a national organization that distributes funding provided by private corporations to support recycling improvement and expansion.

Both single-stream composition audits and recycling container monitoring programs would be especially informative in the Benton County communities that have outsourced all recyclables collection and marketing to their haulers as part of their collection contracts.



Exhibit 2-1 Summary of Options for Regional MRF Development

	<u>Option 1</u>	<u>Option 2</u>	<u>Option 3</u>	<u>Option 4</u>	<u>Option 5</u>	<u>Option 6</u>	<u>Option 7</u>
	Two MRFs (One per District)	Two MRFs (One per District)	One Regional MRF	One Regional MRF	One Regional MRF	One Regional MRF	One Regional MRF
<i>Process Type</i>	<i>Single Stream</i>	<i>Dual Stream</i>	<i>Single Stream</i>	<i>Dual Stream</i>	<i>Single Stream</i>	<i>Dual Stream</i>	<i>Multi-Stream</i>
<i>Required Feedstock</i>	<i>Residential</i>	<i>Residential</i>	<i>Residential</i>	<i>Residential</i>	<i>Res &amp; Com'l</i>	<i>Res &amp; Com'l</i>	<i>Res &amp; Com'l</i>
<b>Design Capacity</b>	17,500	17,500	35,000	35,000	70,000	70,000	70,000
<b>No. of MRFs</b>	2	2	1	1	1	1	1
<b>Acres (per MRF)</b>	3.5	2.5	4.0	3.0	6.0	6.0	6.0
<b>Capital Cost</b>	\$29,950,000	\$17,960,000	\$21,460,000	\$12,950,000	\$27,380,000	\$19,430,000	\$29,050,000
<b>Net Annual Cost</b>	\$3,380,000	\$2,120,000	\$1,890,000	\$900,000	\$2,270,000	\$1,000,000	\$2,380,000
<b>Tons</b>	35,000	35,000	35,000	35,000	70,000	70,500	70,500
<b>Per Ton</b>	\$97	\$61	\$54	\$26	\$32	\$14	\$34

Notes: Capital cost does not include land acquisition



## 3. ORGANICS RECOVERY POTENTIAL

### 3.1 INTRODUCTION TO ORGANICS RECOVERY

This section provides an overview of the potential for diverting organic materials from municipal waste streams in the Northwest Arkansas region. Initial stages to the development of this section included meetings with key stakeholders within the Boston Mountain and Benton County Solid Waste Districts (Districts) to define political interest and financial mechanisms for the infrastructure and programmatic changes necessary to increase the recovery of organic material.

An analysis of current market conditions, annual tonnages, existing programs and facilities, as well as results from an assessment to determine large generators of organic material, were utilized to construct potential scenarios the region may consider for collecting and processing organics. These scenarios are ranked by relevant criteria and include potential barriers to implementation. Additionally, a general list of recommendations for increasing organics recovery rates is provided. These include source reduction options such as the expansion of food recovery networks.

#### 3.1.1 PROCESSING AND COLLECTION TECHNOLOGIES

The diversion of organic materials from municipal waste streams requires adequate infrastructure for collection and processing. Other requirements include programs for public engagement and recovery, regional expertise in composting and management of the program, and markets in which to sell the finished material. In terms of infrastructure, methodologies for composting organics can range from small scale windrow systems that handle yard waste only, to complex indoor facilities utilizing in-vessel technologies and anaerobic digesters. For the region, there are many opportunities and options for increasing the recovery rate of organic material. Major technologies that were considered during this study are outlined in Table 3-1 with brief descriptions. Section 3.4 provides further details for the technologies selected as scenarios suited for the Northwest Arkansas region.

**Table 3-1 Potential Composting Technologies**

Composting Method	Description
Turned Windrow (TW) (Unaerated or Aerated)	TW composting involves piling feedstock materials into elongated rows either outside or in a building and turning them periodically based on time and temperature factors. This has been the most common method of composting in the U.S. for yard waste and source-separated food waste, primarily because it has lower capital and operating costs than the aerated static pile or in-vessel methods described below.
Aerated Static Pile (ASP)	ASP composting involves placing air blowers and/or ducts under a pile of organic material to maintain aerobic conditions. The process was originally developed for biosolids composting and is generally less capable of handling diverse feedstocks than TW. The pile is capped with an insulating blanket of wood chips or other material and not disturbed until the active composting process is complete. ASP typically provides better odor control than TW composting because materials are not disturbed during the active phase and the insulating blanket helps reduce odor emissions.
Modified Static Aerobic Pile (MSAP)	MSAP composting is a hybrid of both TW and ASP composting methods. Windrows are inoculated with a blend of microorganisms, then covered with an insulating blanket of organic material and not turned during the initial 30 days. Aerobic conditions are maintained in the compost pile without needing mechanical turning or forced aeration.

# ORGANICS RECOVERY POTENTIAL

Composting Method	Description
In Vessel (IV)	IV composting refers to enclosed systems or bioreactors such as large rotating tubes or elongated bays with mechanical turning machines and forced aeration systems. Such systems are typically used to compost manures, food waste, and biosolids, with very large systems also used to process MSW. Because the process is often enclosed in a building, problems with birds or other vectors are limited. Also, odor control technologies are used to treat process air and minimize odors.

In addition to examining processing technologies, this study included the assessment of multiple collection methods to ensure adequate feedstock for any regional or local facility being considered. Those considered within this analysis included commercial, industrial, and curbside collections, as well as drop-off sites. They are further discussed in Section 3.3.

### 3.1.2 ORGANICS COLLECTIONS AND PROCESSING IN NORTHWEST ARKANSAS

The current collection and processing of organic materials in the Northwest Arkansas region is primarily limited to yard waste. Table 3-2 summarizes the municipalities that offer curbside yard waste collection in the region.

**Table 3-2 Yard Waste Collection Programs in Northwest Arkansas**

District	Municipalities with Curbside YW Collection	Population Served
Boston Mtn	3	170,959
Benton Co	5	146,455
<b>Total</b>	<b>8</b>	<b>317,414</b>

Baseline data presented in Section 1 revealed significant potential for diverting additional organic materials from disposal. In particular, the waste generation and composition analysis estimates there are almost 50,000 tons of food scraps generated annually in the combined residential and commercial sector plus another 28,000 tons of both yard wastes and other compostable organics (mainly low-grade papers). These totals for 2018 are shown in Figure 3-1 and have been used for planning purposes.

**Figure 3-1 2018 Organic Material Diversion in Northwest Arkansas Region**

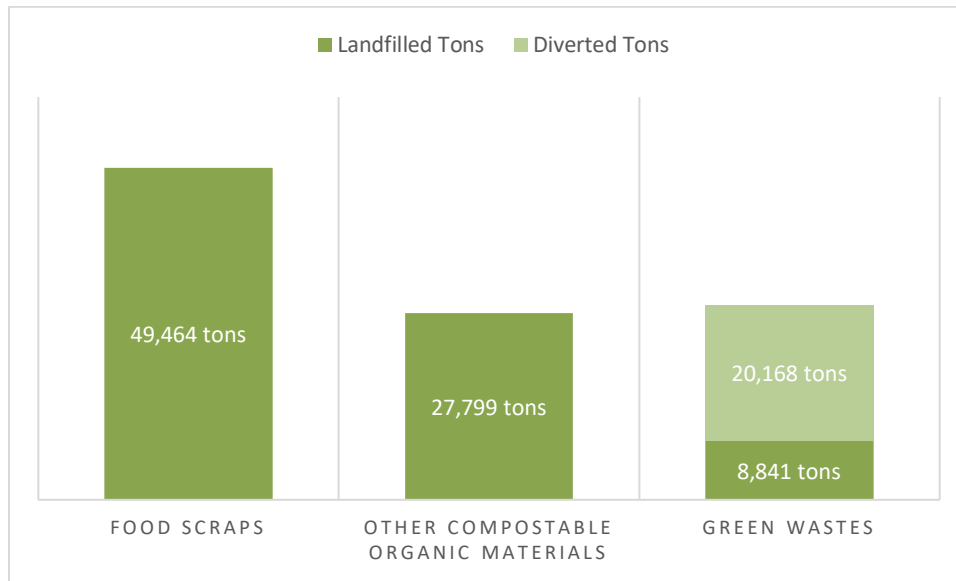

[1] See Section 1.3.1 for further information.

[2] Note: Data from 2018 and thus not inclusive of food scraps diverted at City of Fayetteville facility that expanded during 2019.

Five organic processing facilities are currently located in the region. These are further defined in Section 3.3.

- ◆ The **City of Fayetteville** operates a MSAP compost facility for source separated organics. This facility is currently the only processor of municipal food waste for the region.
- ◆ In the City of Tontitown, the **Eco-Vista Composting Program** is owned and operated by Waste Management (WM) and accepts yard waste materials for processing.
- ◆ The **City of Bentonville** operates a windrow compost facility that processes residential yard waste. Feedstock arrives through collections provided by Republic Services and self-haul to site.
- ◆ The **Benton County Solid Waste District** operates a district composting program, processing dropped off materials with a chipper the yard waste materials brought in from businesses or residents of the county.
- ◆ The **City of Rogers** operates a yard waste processing facility only for citizens of Rogers.

## 3.2 MARKET CONDITIONS

The market for collecting and processing organic materials is growing. According to EPA data the total MSW composted in the U.S. in 2017 was 27 million tons. Approximately 24.4 million tons were yard trimmings, and 2.6 million tons were food waste.<sup>1</sup> Recycling of organic materials was once viewed with little value. However recent trends reveal increasing demand for including this service in municipal solid waste programs. Composting operations that previously offered free yard waste compost products to area residents are now recognizing it as a value-added commodity with profitable applications when standards are clearly defined, tested, and met. The addition of other source-separated materials, such as food waste,

<sup>1</sup> United States Environmental Protection Agency. National Overview: Facts and Figures on Materials, Wastes and Recycling. [www.epa.gov/facts-and-figures-about-materials-waste-and-recycling/national-overview-facts-and-figures-materials](http://www.epa.gov/facts-and-figures-about-materials-waste-and-recycling/national-overview-facts-and-figures-materials)

# ORGANICS RECOVERY POTENTIAL

---

can improve the nutritive value of compost; however, most facilities that handle food waste prefer receiving only pre-consumer food waste from commercial and institutional generators, not from residential sources. This is due to the increased potential for non-compostable contamination from the residential material. As general awareness grows regarding the uses, benefits and value of compost, demand has grown and composters are producing a wide range of products for general and specialized uses for landscaping, sport fields, golf courses, disease suppression, erosion control, soil restoration, and agricultural.

## 3.2.1 CURRENT MARKET DRIVERS

On a national level, current market drivers for the diversion and recycling of organic material include landfill bans, mandated diversion goals, increased availability of compostable foodservice products, and lower tip fees than those of landfill disposal. These have increased the demand for processing facilities that accept diversified feedstocks and foster private sector operational and ownership interest. Advances in government agency procurements, as a response to organic material bans and mandated diversions, have also increased private sector interest in both the ownership and operations of compost facilities. The State of Arkansas 2014-2024 Statewide Solid Waste Management Plan established a goal for recycling and diverting materials from landfill disposal, requiring districts to identify strategies and goals in their annual assessments.

## 3.2.2 CO-LOCATION TRENDS

Composting facilities are increasingly being located adjacent to landfills and transfer stations – as opposed to stand-alone facilities. The majority of facilities in Northwest Arkansas are co-located with a landfill, recycling collection center, or transfer station. Landfills prove to be ideal, due to having environmental investigation and infrastructure already completed. This may include road access for heavy-duty vehicles, civil engineering, scale and weight systems, utilities, and open space that can reduce the cost of compost facility development. Existing equipment may readily support operations with scales, recordkeeping, maintenance, employee facilities, and wells for water that are required. Transfer stations and material recovery facilities with co-existing compost operations take advantage of the delivery of materials, often finding that private sector haulers delivering yard waste materials will utilize back-haul mileage to then deliver finished compostable products to customers.

On-farm composting facilities continue to be a viable marketplace for the diversion and recycling of organic materials. In addition to opportunities to compost their own materials, on-site facilities provide an outlet to generate revenue from off-farm materials, such as neighboring municipal yard waste, which can be an important bulking agent for farm wastes. These facilities also allow for revenue through the sale of finished products.

## 3.2.3 ECONOMY OF SCALE

The commercial viability of composting is affected by economies of scale. The capital-intensive nature and permit regulations allow for larger facilities to absorb costs and operate with more financial stability. Additionally, this allows for facilities to be designed to process a variety of feedstocks and create a more diverse number of end products, like those meeting the specifications of state transportation departments, the agricultural industry, nursery and horticulture, and the turf management industry.

## 3.2.4 QUALITY STANDARDS

Technological improvements in the monitoring of the breakdown of material and regulations on testing multiple parameters of the final product have increased the value of composted organic materials and have improved efficiency in operations. This includes addressing the physical contamination in food waste, both pre-consumer and post-consumer materials.

It is important to note the increased interest in per- and polyfluoroalkyl substances (PFAS) in finished compost. PFAS are man-made chemicals that have been manufactured and used in a variety of industries

## ORGANICS RECOVERY POTENTIAL

since the 1940s. These chemicals are known to compound and therefore have been detected in compost resulting from certain feedstocks. Current research has identified this as an additional parameter that may be considered for future regulation. Concerns are impacting the willingness of knowledgeable composters to accept compostable packaging that may contain PFAS.

### 3.2.5 DEMAND IN NORTHWEST ARKANSAS

There are numerous industries located in Northwest Arkansas with corporate sustainability policies that require general waste reduction measures, as well as the diversion of organic materials from their waste streams. In addition, the Arkansas Department of Environmental Quality (ADEQ) requires counties to identify methods for increasing diversion rates from their municipal solid waste system and annually report increases. In addition to these state mandates, private sector interest in recycling food waste as a part of community-wide sustainability and green programming has led to business development in the collections of food waste for the region.

This increase in demand is currently being met by one identified hauler, with current significant capacity limitations and one limited-capacity municipal processing facility. Food Recycling Solutions, Inc. provides food waste collection services from corporate events and regional caterings. These collections are being processed at the City of Fayetteville's compost facility. As noted earlier, this facility is the only ADEQ permitted food waste processor in the region (Type O). The 3.1-acre facility offers limited expansion capacity and is not capable of processing the tonnage of food and yard waste material as counties continue to meet diversion rates required by ADEQ, corporate, and citizen interest.

### 3.3 CURRENT COLLECTION AND PROCESSING PROGRAMS

Five processing facilities are currently operating in Northwest Arkansas.

- ◆ **Boston Mountain SWMD** is home to the City of Fayetteville Compost Facility and the Eco Vista Landfill compost facility.
- ◆ **Benton County** hosts the Benton County SWMD yard waste facility, the City of Bentonville's compost facility, and the City of Rogers yard waste facility.

The City of Rogers' facility serves only its citizens, mulches the material and provides back to its citizens, and is not a permitted facility. The other facilities are discussed further below.

#### 3.3.1 CITY OF FAYETTEVILLE COMPOST FACILITY

The City of Fayetteville launched a commercial food waste composting pilot in 2016 as a part of their Solid Waste Reduction, Diversion, and Recycling Master Plan to determine the feasibility of a citywide commercial food waste collection and composting program. Currently, this facility, located on a limited capacity 3.1-acre concrete pad, utilizes a MSAP windrow method. Previously the city maintained a windrow yard waste composting facility on the site. To accommodate the inclusion of food waste, the city utilized a proprietary microbial inoculate that expedites the composting process and minimizes windrow turning requirements. Figure 3-2 shows the compost processing area.

# ORGANICS RECOVERY POTENTIAL

Figure 3-2 City of Fayetteville Compost Facility



Initial feedstocks for this facility included the identification of 11 different large generators throughout the community. Food waste was collected by the city utilizing 64-gallon containers either unlined or lined with biodegradable bags. Currently, the facility receives feedstocks from multiple drop-off locations, a new commercial curbside collection program provided by the city, and through a private food waste hauler, Food Recycling Solutions, Inc. This small enterprise has limited capacity for collections due to fleet constraints and currently focuses on servicing corporate events and on a small number of commercial clients. Marketing of the resulting compost commodity occurs through the city’s website and via general outreach programming. Table 3-2 provides an overview of the operations.

Table 3-3 City of Fayetteville Compost Facility Program Overview

Location	Processing Technology	Operational Hours	Material Accepted	Fees	Compost Price
<b>City of Fayetteville Compost Facility</b> Address: 1708 S. Armstrong Ave.	Modified Turned Windrow (inoculant)	Tues.-Thurs.: 8 a.m. - 3 p.m.	Yard Waste	Free for Residents	YW Compost: \$25/2.5 yd <sup>3</sup>
	Capacity: 3.1 acres	First Sat.: 8 a.m. - noon (Nov-Mar) First and Second Sat. 8 a.m. - noon (Apr-Oct)	Food Waste	\$5 - \$15 for Non-residents	FW Compost: \$35/2.5yd <sup>3</sup> Mulch: \$10/2.5yd <sup>3</sup> Delivery: \$75/2 yd <sup>3</sup> (FW Compost) *
<b>Drop-Off Locations</b>					
<b><i>DROP-OFF LOCATION:</i></b> <b>Marion Orton Recycling Center</b> Address: 735 West North St.	Transfer Station	Mon.-Sat.: 8 a.m. – 5 p.m.	Food Waste	No tip fee	—
<b><i>DROP-OFF LOCATION:</i></b> <b>Happy Hollow Recycling Center</b> Address: 1420 S. Happy Hollow	Transfer Station	Sun.-Sat.: 24hrs	Food Waste	No tip fee	—



# ORGANICS RECOVERY POTENTIAL

Food Waste Collections Services					
City of Fayetteville	Commercial (Public)	Mon., Wed., Fri.	Food Waste	\$14.87/month (incl. 64-gal cart)	—
Food Recycling Solutions, Inc.	Commercial and Residential (Private)	Varies	Food Waste	Varies	—
Yard Waste Collections Services					
City of Fayetteville	Single Family Residential (Public)	Weekly	Yard Waste	TBD	—
<i><b>Food Waste Materials Accepted:</b> Fruits and vegetables, coffee grounds and tea with filter, consumable liquids, dairy products, bread and grains, eggs, compostable paper products, cooked meats and fish, wooden skewers and toothpicks, processed foods, and BPI certified compostables.</i>					
<i><b>Yard Waste Materials Accepted:</b> Grass clippings, leaves, brush no greater than 4 ft in length, limbs no greater than 5 inches in diameter</i>					

\*City now offers delivery of compost to Fayetteville residents. Free and reduced pricing determined on case by case basis.

According to the 2019 Annual Report, the facility processed 8,031 tons of organic materials, selling over 4,351 cubic yards of finished compost and 6,390 cubic yards of mulch. It is important to note the city continues to transition to increase food waste as a feedstock and the new commercial food waste curbside collection program will increase this material diversion.

### 3.3.2 ECO-VISTA LANDFILL AND COMPOST FACILITY

Co-located at the Eco-Vista Landfill, this compost facility, owned and operated by Waste Management, processes yard waste via grinding for mulch and windrowing into compost. Portions of this recycled material may be utilized as an alternative daily cover for landfill operations, as well as available for retail sale. Current agreements with the City of Tontitown and City of Springdale allow for the free drop-off of residential yard waste for citizens. Figure 3-3 provides a view of the Eco-Vista site.

**Figure 3-3 Eco-Vista Landfill & Compost Facility**



Multiple private haulers in the area offer curbside yard waste collection to citizens. Depending upon contractual terms, some tip materials at the Eco-Vista facility. Table 3-3 provides an overview of the operations.



# ORGANICS RECOVERY POTENTIAL

Table 3-4 Eco-Vista Landfill Yard Waste Compost Facility Program Overview

Location	Processing Technology	Operational Hours	Material Accepted
<b>Eco Vista, LLC Disposal Management Facility</b> Address: 2210 WM Drive Springdale, AR 72762	Mulch Grinding / Windrow	Mon.-Fri.: 8 a.m.-4 p.m.	Yard Waste
	Capacity TBD	Comm & Industrial Mon.-Fri.: 4:30 a.m.-5 p.m.	
<b>Collections Services</b>			
<b>Waste Management</b>	Single Family Residential (Public)	Varies	Yard Waste
<b>Private Haulers</b>	Residential & Commercial Curbside	Weekly	Yard Waste
<i><b>Yard Waste Materials Accepted:</b> Grass clippings, leaves, brush no greater than 4 ft in length, limbs no greater than 5 inches in diameter.</i>			

It should be noted that while not a designated processing facility, the City of Johnson provides curbside yard waste chipping services for residents at designated times each month. This allows for the mulching of materials and landfill diversion.

### 3.3.3 CITY OF BENTONVILLE COMPOST FACILITY

The City of Bentonville operates a 10-acre windrow composting facility for residents only at 2000 NW A Street. These turned windrows recycle multiple feedstocks to include wood chips, biosolids, and yard waste. Figure 3-4 shows the Bentonville facility.

Figure 3-4 City of Bentonville Compost Facility



This facility offers a material drop-off area for city residents. Additionally, Republic Services provides curbside, residential, carted yard waste collection for a fee. Table 3-4 provides an overview of the operations.

# ORGANICS RECOVERY POTENTIAL

**Table 3-5 City of Bentonville Compost Facility Program Overview**

Location	Processing Technology	Operational Hours	Material Accepted	Fees	Compost Price
<b>City of Bentonville Compost Facility</b>  Address: 2000 NW A Street Bentonville, AR 72712	Mulch Grinding / Windrow	Mon.-Sat.: 8 a.m.- 4 p.m.	Yard Waste (residential only / no commercial)	Free (residents only)	Bagged: \$4/40lb Screened: \$20/yd <sup>3</sup> Unscreened: Free to res Mulch: Free to res Bulk: \$20/load
	Capacity TBD				
<b>Collections Services</b>					
<b>Republic Services</b>	Carted Residential (Private)	Varies	Yard Waste	Varies	—
<b>On-Site Drop-Off</b>	Residential Only	Mon.-Sat.: 8 a.m.- 4 p.m.	Yard Waste	None	—
<i><b>Yard Waste Materials Accepted:</b> Grass clippings, leaves, brush no greater than 2 inches in diameter.</i>					

### 3.3.4 BENTON COUNTY SOLID WASTE DISTRICT YARD WASTE FACILITY

The Benton County Solid Waste District accepts mixed yard waste consisting of brush, leaves, and/or grass clippings at their facility. Curbside pickup is available from the private hauler Orion Waste Solutions. Citizens utilizing curbside must purchase brown kraft yard waste bags from Garner Building Supply or Orion Waste’s office complex for a small fee. Table 3-5 provides an overview of the operations.

**Table 3-6 Benton County Solid Waste District Regional Compost Facility Program Overview**

Location	Processing Technology	Operational Hours	Material Accepted	Fees	Compost Price
<b>Benton County Solid Waste District Yard Waste Facility</b>  Address: 5702 Brookside Rd., Bentonville, AR 72713	Chipper to Mulch	Tues.-Sat.: 8-11 a.m., 12:00-3:00 p.m.	Yard Waste (residential and businesses within Benton Co.)	\$5/yd <sup>3</sup>	Mulch: Free to residents
	Capacity TBD				
<b>Collections Services</b>					
<b>Orion Waste Solutions</b>	Carted Residential (Private)	\$2/bag	Yard Waste	\$2/bag	—
<b>On-Site Drop-Off</b>	Residential Only	Tues.-Sat.: 8 a.m.- 3:30 p.m.	Yard Waste	\$5/yd <sup>3</sup>	—
<i><b>Yard Waste Materials Accepted:</b> Leaves, grass, brush, limbs, and tree trunks up to 24 inches in diameter (root balls and tree stumps not accepted).</i>					

# ORGANICS RECOVERY POTENTIAL

---

## 3.4 VISION FOR A REGIONAL SYSTEM

Analysis conducted during this study revealed two potential scenarios the region may consider to increase diversion rates of organic materials from disposal. The first scenario is the development of a three-county regional facility that may include a multi-phased approach for implementation. The second scenario resulting from this study is the expansion of existing facilities and processing technologies to accommodate the organic materials generated within the area.

An important component to understanding these scenarios relates to the availability of feedstock, expansion capacity, and permitting suitability of existing facilities. The following section provides a summary of an analysis conducted to identify potential commercial and institutional sectors that may support these scenarios for a regional system.

### 3.4.1 REGIONAL FACILITY ANALYSIS

The collection and processing of organic materials varies among jurisdictions in the Northwest Arkansas Region. Current facility technologies and feedstocks are primarily designed to process yard waste. The diversion of yard waste is common throughout the region. Multiple private haulers within the area currently provide collection services for yard waste and deliver to one of the four designated facilities noted in this section. While there is room for additional tonnages to be diverted from the stream, nearly 70% is currently being processed into commodities for the area.

The diversion of food scraps and other compostables from the regional waste stream is more limited. Currently, only one facility with limited processing capacity accepts these feedstock materials. As discussed previously, collections for the materials are even more constrained, with the capacity being limited to one private hauler and one municipality focused only on commercial waste.

### 3.4.2 ORGANICS GENERATOR ASSESSMENT

To understand the potential feedstocks for a regional system, a generator assessment was conducted for Benton, Madison, and Washington Counties to identify commercial and industrial material sources from six different sectors. It should be noted that results from this assessment should be utilized as a planning tool and not a measurement tool. The methodology selected for determining generator waste estimates were based on generation rates common in the industry and built upon research resulting from the United States Environmental Protection Agency and multiple studies. These rates were multiplied by employee data pulled from NAICS and FIPS codes for all three counties. Results were then compared to those defined by the CalRecycle Waste Characterization Tool for comparable comparisons. Table 3-6 presents the estimated tonnage of organic material generated annually by sector.

# ORGANICS RECOVERY POTENTIAL

**Table 3-7 Organics Generator Assessment Results (Annual Tonnage by Sector)**

SECTOR	ESTIMATED TONS GENERATED
FOOD MANUFACTURERS AND PROCESSORS	15,280
FOOD WHOLESALE AND RETAIL	8,558
EDUCATIONAL INSTITUTIONS	3,400
HOSPITALITY INDUSTRY	2,277
HOSPITALS AND ASSISTED LIVING FACILITIES	6,500
RESTAURANTS AND FOOD SERVICES	30,820
<b>TOTAL</b>	<b>66,835</b>

This initial data may be important as the region moves forward with determining the best scenario for recycling food waste.

### 3.4.3 ORGANICS SCENARIO 1: NEW REGIONAL ORGANICS PROGRAM

Based on a comprehensive analysis of existing facilities, current and potential feedstocks, political support, and funding mechanisms, the first scenario evaluated in this planning process is to undertake a multi-phased approach to regional organics processing.

Currently, no facility exists to process the tonnage of materials for both the Boston Mountain and Benton County Solid Waste Districts. Based upon data collected through this study, the region may consider the construction of a new region-wide organics processing facility with a supporting collections system that allows for adequate feedstock.

To remain economically viable, it is recommended the technology for a regional facility be MSAP or Turned Windrow. These foundational technologies can allow for future modifications but will minimize upfront capital costs and allow for a more reasonable processing price per ton. Additionally, they will allow for a multi-phased approach for expansion with additional feedstock tonnage. The owner / operator structure of this facility could vary based upon political will, government capacity, and private sector interest. An overview of assumptions utilized in an initial pro forma is presented in Table 3-7.

**Table 3-8 Regional Composting Facility Pro Forma Calculation Assumptions**

<b>Capture Rate</b>	30%
<b>Design Technology</b>	Turned Windrow
<b>Design Capacity</b>	10,000 tons/year food waste 12,000 tons/year yard waste

Table 3-8 defines the financial estimates for constructing a facility based on the prior assumptions. The capital cost does not include land acquisition and assumes a site with suitable initial topography. It should be noted that these are estimates for planning purposes and would require refinement and further analysis

## ORGANICS RECOVERY POTENTIAL

---

and verification prior to implementation. It is notable that the suggested tip fee for organic materials is lower than regional disposal options.

**Table 3-9 Regional Composting Facility Financial Estimates**

<b>Acres</b>	9
<b>Capital cost</b>	\$1,500,000
<b>Annual Cost</b>	\$650,000
<b>Compost Revenue</b>	(\$125,000)
<b>Net Annual Cost</b>	\$525,000
<b>Tons of Food Waste &amp; Yard Waste</b>	22,000 tons
<b>Price Per Ton</b>	\$24

With limited collection infrastructure currently in the region, it is recommended results from the generator assessment be utilized to identify feedstock sources that could be considered easy to obtain and readily available. This is often referred to as the “low hanging fruit.” This model was successfully utilized by the City of Fayetteville in their pilot project that identified larger, commercial generators for initial feedstock. Once the program is viable, feedstock sources can be expanded into other areas of the community, potentially fostering economic expansion and job growth.

An additional “low hanging fruit” that may prove viable for collecting feedstock would be the integration of food waste into community drop-off site programming for both the Boston Mountain and Benton County Solid Waste Districts. This structure is widely practiced in rural and suburban areas in certain parts of the U.S.

Generating the capital required for building a regional facility is directly linked to the overarching ownership structure determined most appropriate for the area. There is currently a growing private sector industry striving to meet compost demands as communities strengthen their waste diversion goals and seek to eliminate food waste and yard waste in landfills. Partnerships between the public and private sector, commonly referred to as Public-Private Partnerships (PPPs), may be considered for this project and often generate greater compost commodity sales and offset costs through combinations of tip fees and grants.

The implementation of a regional facility will require a thorough evaluation of local policy and programs to understand potential changes necessary to support funding sources. These may include revisions to solid waste ordinances to require the diversion of food waste and yard waste from landfill, as well as programmatic changes to collection contracts and franchise programming for municipalities.

There are several key advantages to developing a regional processing facility that could be expanded as demand for processing of materials increased. These advantages include:

- ◆ Regional facilities can achieve the economies of scale necessary, attracting more private sector interest in partnerships.
- ◆ Larger facilities are more capable of producing value added products (e.g., special blends and bagged products).
- ◆ Composting equipment is generally sized for larger free-standing facilities.
- ◆ Regional facilities generally can be distanced from local politics and allow for more partnership potential and stabilized financing.
- ◆ Increased options for facility location to adequately serve the region.

## ORGANICS RECOVERY POTENTIAL

---

- ◆ Capital and operational costs are consolidated through the construction of one facility.
- ◆ Further advantages may be determined depending upon the overarching ownership and operational structure for the facility.

There are also several challenges associated with the construction of a regional facility for Northwest Arkansas:

- ◆ Identification of a large, suitable site that allows for capacity expansion.
- ◆ Coordination of collection of materials to the facility (e.g., convenience center drop-off sites).
- ◆ No current political system or entity is in place that could manage or has been identified to manage regional solid waste infrastructure.
- ◆ Determining financing requirements and the ownership, management, and operations of the facility.
- ◆ Coordination of policies and programs for collection of feedstock materials across the region (e.g., municipal collection contracts, landfill bans, education, and outreach).

### 3.4.4 ORGANICS SCENARIO 2: EXPANSION OF EXISTING PROCESSING FACILITIES

A second option the region may consider for increasing the diversion of organic materials is the expansion of existing facilities to ensure each Solid Waste District has at least one facility with the capacity and technology to process food and other compostable waste.

As presented in Section 3.3, both the Boston Mountain and Benton County Solid Waste Districts have two operational facilities that could be evaluated for expansion of feedstock and capacity requirements. Further studies would need to be conducted to understand the implications and limitations at each potential facility, as well as operator (both public and private sector) interest in expansion.

There are numerous advantages to expanding existing facilities. These include:

- ◆ Expansion builds upon existing ownership, political, and financial infrastructure.
- ◆ Capital costs will be eliminated (e.g., land, equipment, etc.).
- ◆ Labor costs are already in place.
- ◆ Altering technology to accommodate feedstock changes will minimize costs.
- ◆ Collections challenges will be minimized and not require cross District coordination.

As with any scenario, there are challenges. These may include:

- ◆ Overall site size would have to be considered to ensure enough capacity.
- ◆ Potential ADEQ facility permitting changes.
- ◆ Potential increases to processing fees or other charges to accommodate new technologies.

## 3.5 OTHER ORGANICS-RELATED RECOMMENDATIONS

Note that the single most important aspect of a regional organics management system involves the ownership and management of the system and associated infrastructure. This issue is addressed in Section (5/6) because it also applies to the regional recycling system and even the regional C&D recycling regime.

In addition to the development of infrastructure for collection and processing organic materials, the region may consider the following additional strategies to improve diversion rates.

### 3.5.1 ORGANICS PROCESSING

The following recommendations will foster support for the development or expansion of processing facilities within the Northwest Arkansas Region and should be considered.



## ORGANICS RECOVERY POTENTIAL

---

- ◆ Establish regional or local organic diversion goals addressing yard waste, food waste and organic compostables and integrate into District mandates.
- ◆ Perform a Waste Composition Study (WCS) for the region to determine actual diversion potential and capacity requirements if planning a regional, multi-district facility.
- ◆ Consider bans on certain organic materials, identified from WCS, from the waste stream.
- ◆ Develop a Collections Plan to accompany any selected processing facility development to ensure adequate feedstock.
- ◆ Integrate composting into District-wide solid waste educational and outreach programming.
- ◆ Support local governments with regional policy templates that encourage the use of compostable materials and disuse of single use items such as plastic straws and bags.
- ◆ Provide grants for municipalities seeking to implement composting pilot projects similar to the City of Fayetteville.
- ◆ Initiate interest in composting of organic materials through residential composting pilot programs (providing supplies and classes on managing backyard composting).

### 3.5.2 ORGANICS COLLECTIONS

Supporting existing or future processing facilities with adequate feedstock will likely expand the current collection system. The following recommendations should be considered when planning.

- ◆ Expand yard waste collection services as a part of collection contracts to all municipalities within the region.
- ◆ Incentivize diversion of yard waste by ensuring diversion costs at any new facility remain below traditional landfill disposal costs.
- ◆ Initiate collection of organic materials at drop-off locations maintained by the municipalities and Districts.
- ◆ Conduct detailed analysis of feedstock potential from area industries to determine potential diversion numbers and ensure the collection of enough material to warrant an organics processing facility.
- ◆ Survey regional restaurants and large facility businesses to determine interest in private hauling/collection of organic materials.
- ◆ Include organics diversion in future outreach and education programming at the District level.
- ◆ Build upon City of Fayetteville's outreach and increase educational opportunities for composting noting community-wide benefits, including the resulting compost.
- ◆ Consider engaging community stakeholders to determine a best location to establish a food waste collection pilot program.

### 3.5.3 ADDITIONAL RECOMMENDATIONS

In addition to the collection and processing infrastructure required regionally to increase diversion rates of organic materials from disposal, the following programmatic and outreach recommendations should be considered.

- ◆ Expand regional food pantries to develop a more extensive food recovery network and promote food waste reduction through public outreach and education.
- ◆ Enhance municipal and District data collection and reporting systems to ensure more accurate baselines for evaluating future diversion rates.
- ◆ Expand solid waste education and outreach programming to support the diversion of organic materials to include food scraps and yard waste.



## 4. C&D RECOVERY POTENTIAL

---

### 4.1 INTRODUCTION TO C&D RECOVERY

Construction & demolition (C&D) debris is a type of waste that has a high potential for reuse and recycling and is a prime material stream for potential waste reduction. C&D wastes are estimated to be a significant volume within Northwest Arkansas. C&D debris includes, among other materials, concrete, brick/block, gypsum wallboard, a variety of lumber and engineered wood, asphalt, soils, land clearing (trees, shrubs, etc.), corrugated cardboard, various durable plastics goods, ferrous and nonferrous scrap metal, and myriad composite materials.

Many of the individual constituents of C&D debris can be reused or managed on the site of generation as road base, erosion control, and ground stabilization, and does not typically require disposal at a solid waste facility. The U.S. EPA's most recent data<sup>1</sup> estimates C&D debris generated in the United States is more than twice the amount of generated MSW, with the majority (more than 90 percent) attributed to demolition. However, national estimates<sup>2</sup> suggest that less than one quarter of C&D debris is landfilled.

Arkansas delineates Class 4 landfills as being able to accept C&D debris, as well as other bulky, inert wastes that are inert and non-putrescible. Due to the characteristics of C&D debris and other acceptable wastes at these facilities, Class 4 landfills have lower environmental control thresholds and are typically less expensive to develop and operate compared to Class 1 landfills for municipal solid wastes. Class 4 landfills therefore may offer lower tipping fees for haulers of C&D materials (which helps to maximize the life of Class 1 landfills for disposal of MSW).

Despite the high national recycling rate – which is largely driven by reuse of very dense materials like concrete and asphalt at the site of generation – there remains a significant amount of C&D debris in the waste stream that must be disposed or recycled offsite. Much of this remaining debris is highly recyclable and in some cases reusable. Many regions across the country have implemented aggressive and successful programs to divert incremental portions of the mixed C&D debris that is generated.

### 4.2 MARKET CONDITIONS

This report focused on the potential for increasing diversion of C&D debris from the Boston Mountain SWD, consisting of Washington and Madison Counties.

#### 4.2.1 C&D DISPOSAL AND COMPOSITION

As estimated in Section 1 of this document, C&D materials requiring disposal in Northwest Arkansas are estimated to be 20 percent of the disposed solid waste stream based on recent and projected regional growth. Table 4-1 provides the estimated volumes of landfilled C&D materials, based on a desktop analysis that incorporates the findings of C&D debris characterization studies recently completed in the Midwest.<sup>3</sup> Note that the amount of C&D debris shown in this table is consistent with the disposed tonnage reported for the most recent 12-month period at the region's only Class 4 landfill. Figure 4-1 provides a breakdown of the estimated composition by major material group. Materials commonly recovered by C&D recyclers when in operation (concrete, rock/gravel, clean wood, roofing materials, and metals) make up over 40 percent of the material stream.

---

<sup>1</sup> EPA Advancing Sustainable Materials Management: 2017 Fact Sheet

<sup>2</sup> EPA Construction and Demolition Debris management in the United States, 2015, March 2020

<sup>3</sup> Fayetteville (AR), Lexington (KY) and demographically comparable areas of the Missouri statewide study.

# C&D RECOVERY POTENTIAL

**Table 4-1 Estimated Regional C&D Waste Composition (2018)**

Materials in C&D Debris	Composition Estimate	Benton Tons	Boston Mountain Tons	Combined Tons
Wood	20.9%	10,069	9,158	19,227
Concrete/Block/Brick/Stone/Tile	15.7%	7,555	6,872	14,427
Gypsum Board	14.7%	7,095	6,453	13,548
Roofing Materials	7.8%	3,755	3,415	7,170
Dirt/Sand/Gravel	5.7%	2,749	2,500	5,249
Metals	3.9%	1,903	1,730	3,633
Green Waste	2.5%	1,183	1,076	2,259
Plastics	4.7%	2,256	2,052	4,309
Other C&D	5.7%	2,757	2,507	5,264
MSW/Other Waste	7.3%	3,521	3,202	6,724
Special Wastes	11.2%	5,387	4,899	10,287
<b>Total</b>	<b>100.0%</b>	<b>48,230</b>	<b>43,865</b>	<b>92,095</b>

Source: Estimates are based on a regional desktop waste stream analysis, described in Section 1.

**Figure 4-1 Estimated C&D Waste Composition by Major Material Group (2018)**

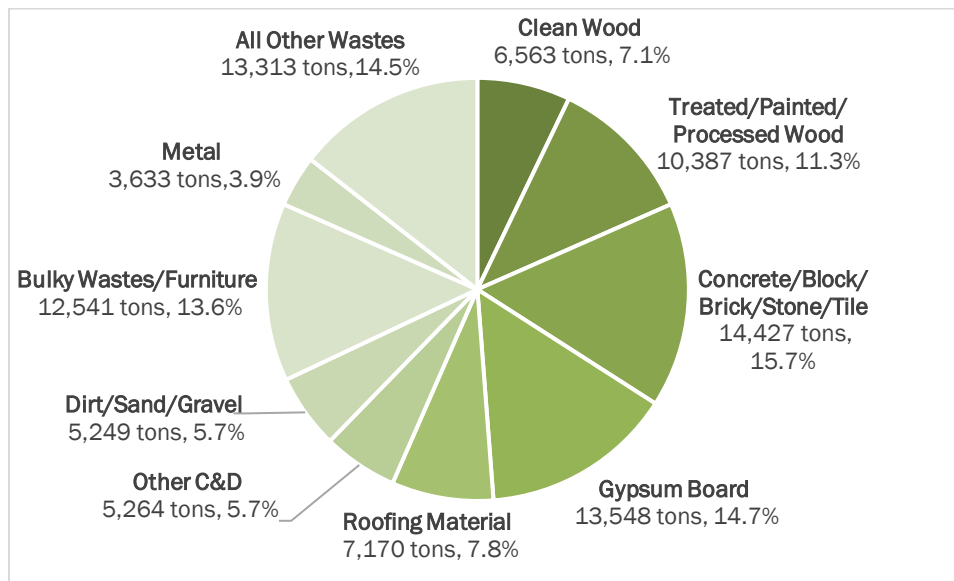

Source: Estimates are based on a regional desktop waste stream analysis, described in Section 1.

## 4.2.2 C&D RECYCLING AND REUSE

There are several businesses in the region that already accept source-separated C&D materials (e.g., concrete, scrap metal) for recycling, and also establishments that divert some construction, renovation and deconstruction materials through salvage and reuse (such as Habitat for Humanity ReStores). These businesses have established an operating and economic niche in the C&D reuse and recycling market. The Boston Mountain SWD includes links to reuse and recycling organizations Earth 911 and Freecycle.org on its website. These existing operations will continue to operate – and in the case of reuse and salvage operations, may have opportunities to expand – should the region take steps to reduce landfill disposal of C&D debris more proactively.

At the current time, there is no large-scale processor capable of accepting mixed C&D debris for processing and recovery of recyclable constituents.

## 4.3 CURRENT COLLECTION PROGRAMS

C&D waste at larger work sites is most commonly collected in open-top roll-off containers or hauled with dump trucks or trucks with long side-dumping trailers. Arkansas state law (APC&EC Regulation 22), charges regional solid waste management boards with the responsibility of licensing all haulers of solid waste within the District. The requirements of licensure as described in the regulation are focused on the basics: properly handling solid wastes, meeting public health and sanitation standards, maintaining insurance, having properly trained and licensed equipment operators, and remittance of a licensing fee.

There are multiple licensed roll-off haulers able to collect C&D debris in the 2-district region. The City of Fayetteville, Boston Mountain SWD, and City of Siloam Springs also offer roll-off collection services municipally, and consequently handle some C&D debris. Further, smaller amounts of C&D wastes can be hauled by exempt self-haulers. In summary, C&D waste collection does not need to be managed by the public sector and operates largely external to the Districts, counties, or local governments.

Boston Mountain SWD’s (and Benton County SWD’s) hauler licensing applications compel haulers to meet the basic licensure requirements described above, require haulers to provide reporting of the quantity of materials collected from each county within the District as well as the disposal location. Reporting of the quantity of material collected is required for management of the state’s mandatory solid waste disposal fee regime. Both districts require haulers to attach a copy of a Pay-As-You-Throw (PAYT) rate structure to encourage recycling in the residential sector. The only mention of C&D debris hauling on either application is inferred for haulers to indicate if they provide “industrial” collection, which typically includes roll-off business and is the primary form of collection from construction, demolition, and renovation work sites. Reporting of C&D wastes also falls under the “industrial” label, and reports are primarily used as a basis for verification of state and district-mandated disposal fees.

## 4.4 CURRENT PROCESSING FACILITIES

There are no C&D recovery and recycling facilities in the Boston Mountain SWMD, and only one in NWA as shown in Table 4-2.<sup>4</sup>

**Table 4-2 C&D Recycling Facilities in NWA (ADEQ Database Search Results)**

Facility Name and Address	County	2019 C&D Recycling
USA Metal Recycling 721 S. Lincoln Lowell, AR 72745	Benton	120 tons of C&D material received 25,700 tons of source-separated scrap metal collected 120 tons of concrete fill removed

Only USA Metal Recycling has an active permit and is operational predominantly as a scrap metal recycler. Information on the USA Metal Recycling web page indicates that some locations (outside of Northwest Arkansas) may accept additional materials for recycling such as wood waste and concrete, but the local operation reported during this study that they do not accept wood waste or concrete as the corporate web site mentions but will accept some clean fiber and plastics as well as scrap metal.

At the time of the first round of stakeholder outreach for this initiative, a firm with national and state C&D processing experience was securing property and planning for startup of a C&D recovery facility in the region. Since that time, they have acquired property, have received the certificate of need from the District and completed the public comment period. Remaining requirements include a minimal zoning change from the City of Springdale and the operating permit from Arkansas DEQ.

<sup>4</sup> Two other C&D recycling facilities in NWA are listed in the ADEQ database, but one is for a facility that was never constructed and another had a voided permit.

## C&D RECOVERY POTENTIAL

---

Based on the lack of options for recycling mixed C&D debris, most of these wastes are being disposed in landfill. The Eco Vista Landfill in Tontitown operates a C&D (Class 4) disposal cell along with its MSW disposal operations. The facility charges the same gate fee for all materials brought in by public haulers, regardless of destination to Class 1 landfill, Class 4 landfill, or Compost Facility. There is no incentive to the hauler for separation of C&D debris at this landfill, although it is hypothesized that use of the Class 4 cell for C&D debris benefits the facility owner because they can charge the same tip fee as for MSW but deposit C&D material in a less costly cell.

### 4.5 ENHANCING REGIONAL C&D DIVERSION

#### 4.5.1 TOOLS AND STRATEGIES TO DIVERT C&D DEBRIS FROM LANDFILL

A wide variety of government strategies, regulations, policies, and programs may be utilized to divert and recycle C&D debris. These can be broadly classified into the following topics, which are organized from lowest degree of regulatory impact to highest.

- ◆ **Outreach and Education:** Districts and local governments can establish the foundation for C&D diversion through the promotion of recycling and reuse operations. Options include development of a C&D recycling and reuse directory of businesses, as well as recycling information made available to developers and contractors as part of the permitting process. These educational items can be assembled and maintained for low cost once it is determined how to publicize and disseminate the materials. Recognition programs that encourage contractors to reuse and recycle C&D may also promote higher diversion. Recognition could be given based on documented diversion for individual projects and/or the use of certain waste reduction practices.
- ◆ **Technical Assistance:** In some parts of the country, local governments have established technical assistance programs and experienced staff (or contractors) that focus partly or entirely on the construction and demolition sector. Staff responsibilities include routine outreach to developers, contractors, recyclers, and local business to track the local market and support voluntary efforts to increase recycling and diversion in this sector.
- ◆ **Recycled-content Building Material Requirements:** Local governments can contribute to increasing the market for recycled and reused C&D debris through their procurement practices. Publicly funded building and renovation projects can be required to use recycled-content building and other materials, which increases demand for recycling of these products. A list of recycled content suppliers can be provided for such projects and included as part of the technical assistance program.
- ◆ **Planning Requirements:** Larger construction and demolition projects already require permitting, environmental review, and other coordination with local government to oversee the project. Many communities have established a requirement for permittees to include a C&D recycling and reuse plan as part of the process. C&D recycling plans can be quite simple (one or two pages), but for larger projects that would be expected to generate a significant amount of debris, more detailed plans can be required. If a requirement for filing C&D recycling plans becomes widespread, over time this can also help to better understand and support the need for processing infrastructure in the region. It will be important in the Northwest Arkansas region not only what to require in any C&D recycling plan, but also to set an appropriate threshold for when such a plan must be submitted. Table 4-3 identifies several threshold tests that have been adopted in other communities that require C&D recycling plans to be prepared.

**Table 4-3 Sample Thresholds for Submittal of a C&D Recycling Plan**

C&D Recycling Plan Trigger	Example of a Threshold	Current Practice
Size of the Project	Greater than 10,000 sq ft.	San Diego (CA) specifies different square footage triggers for residential and commercial construction and renovation projects [1]
Cost of the Project	Greater than \$115,000 value	San Jose (CA) has separate thresholds for residential and commercial construction and renovation projects [2]
Amount of Waste to be Generated by Project	Greater than 10 tons	Chicago (IL) requires recycling of 50 percent of the weight of wastes generated [3]

[1] San Diego municipal code Article 6

[2] San Jose municipal code Chapter 9.10, Part 15

[3] Chicago municipal code Article XIV, Section 11-4-1905

◆ **Reporting Requirements:** Either in conjunction with, or in place of, C&D recycling plans, communities could require more specific reporting about the amount of C&D debris being collected from individual projects. Reporting may be considered unfavorable by the business community because it adds time and cost to any project, so reporting requirements should be considered carefully. Simple reports could be required by the permittee; or some local systems leverage their local private hauling framework to provide reports on C&D waste collection and recycling. However, thoughtful and consistently completed reports would be expected to greatly improve the region’s understanding of the amount of C&D debris, the value of projects, and the reasonableness of increasing diversion requirements in this sector. Table 4-4 shows one common breakdown of the types of C&D projects that generate different waste profiles and that would drive more targeted diversion programs and policies.

**Table 4-4 Regional C&D Data Needs from Enhanced Reporting**

		Sector	
		Residential ↓	Non-residential ↓
<b>Activity</b>	Construction ⇨ Demolition ⇨ Renovation ⇨	<b>Data Needs:</b> Tonnage Project Value Composition/Recyclability	

◆ **Diversion Requirements:** Diversion requirements can be established to set a minimum target for the actual level of reuse and recycling to be achieved over the course of a construction project. Public education, planning requirements, and reporting requirements are helpful to inform the local governments and to stimulate voluntary recycling of C&D. However, setting an actual diversion requirement may impose additional efforts and cost incurred by a developer that would not be necessary in the absence of the requirement. Many local governments have established requirements that are based on similar thresholds as described for submittal of a recycling plan. Table 4-5 presents some examples of diversion and recycling requirements.

## C&D RECOVERY POTENTIAL

Table 4-5 Sample Diversion Requirements

Municipality	Diversion Requirement
Alameda County, CA	100% of concrete 50% of all other C&D debris
Portland, OR	Must provide source-separated recycling of wood, cardboard, green wastes, scrap metal, and rubble
Chicago, IL	50% of all “recyclable materials”

- ◆ **Deconstruction Requirements:** Deconstruction refers to a more orderly dismantling of built structures for the purpose of increasing salvage, reuse, and recycling of materials in the structure. For demolition projects, some cities have established a requirement to evaluate and provide deconstruction services. For example, Berkeley (CA) requires salvage of all recoverable materials prior to demolition. Such requirements may impose obligations on the demolition contractor to publicize the availability and add time for material salvage. A city can support this notification function by maintaining a list of such businesses.
- ◆ **Recycling Deposits for Project Developers:** Some cities have enacted financial deposits to be posted by permit holders as a commitment to achieve diversion targets. Such deposits are often linked to planning requirements. When deposits are required, permit holder must document that they have performed according to their diversion plan, usually by compiling and submitting receipts or other records showing where and how the C&D wastes generated in their project were recycled or reused. Some or all of the deposit is returned upon satisfactory performance of the diversion goal or other performance requirement. Table 4-6 identifies three cities with deposit programs.

Table 4-6 Cities with a C&D Recycling Deposit Program

City	Deposit	Range
Long Beach, CA	3 percent of project value	Min \$1,500, Max \$10,000
San Diego, CA	\$0.20 to \$0.70 per square foot	Min \$200, Max \$40,000
Plano, TX	\$0.15 to \$0.25 per square foot	Max \$11,250

- ◆ **Economic Incentives for Licensed Haulers:** Although not currently an option in Northwest Arkansas, and limited primarily to California, the hauler licensure system could theoretically be enhanced to a more formal franchise system that imposes C&D recycling requirements on the franchised haulers rather than on the permit holders. A franchise is a grant of the right to provide collection, disposal, and processing services to a region, and so is like the licensure requirement currently in place in Arkansas through the districts. A franchise can be exclusive (i.e., only one provider) or non-exclusive (multiple providers). A primary difference between a franchise and the current system of licensure in Northwest Arkansas is that a franchise holder can have more stringent operating requirements placed on the franchise, and can be required to remit a significant franchise fee to the issuing government. With a more flexible franchise fee capability, franchise holders can be given incentives to direct C&D debris (and other recyclables) away from landfills in return for paying a lower franchise fee. Franchised collection agreements can also set collection rates in such a way as to influence the decision of a waste generator to dispose of recycling materials.
- ◆ **Market Development:** State and local governments could potentially undertake efforts to recruit new business to the region that provide a particular good or service. In the C&D recycling space, there are regions of the country that have local recyclers of carpet, gypsum drywall, asphalt shingles,



and other materials. Typically, there are other enabling factors to recruit and establish such businesses (e.g., assurance of a sustainable supply of feedstock, favorable state regulations on the handling and recovery of the material, etc.).

- ◆ **Processing Requirements (or Landfill Ban for Mixed C&D Debris):** A final, aggressive option for increasing the diversion of C&D debris is to require mixed C&D loads be processed at a recycling facility to recover materials prior to disposal. Essentially a landfill ban on mixed C&D materials, processing requirements have been established primarily at the state government level. A brief description of the C&D debris disposal ban in Massachusetts is shown in the following text box.

### C&D Debris Disposal Ban in Massachusetts

In Massachusetts, 310 CMR 19.000 describes the state's disposal ban of the following C&D debris materials:

- ◆ Asphalt pavement,
- ◆ Brick/block,
- ◆ Concrete,
- ◆ Clean gypsum wallboard,
- ◆ Ferrous and non-ferrous metals,
- ◆ Cardboard,
- ◆ Green waste/land clearing debris, and
- ◆ Treated and untreated wood and wood waste.

As a result of this ban, all mixed loads of C&D must be delivered to one of the state's 17 C&D recycling facilities. While this requirement has increased C&D recycling rates, the aggregate recovery rate for C&D recycling facilities was reported to be 18.7 percent in 2016. Establishing a network of C&D recycling facilities in Massachusetts has been politically less challenging due to the dramatically different waste market in that state compared to Northwest Arkansas. Massachusetts' primary waste disposal option is mass-burn waste-to-energy (WTE) facilities rather than landfills. WTE facilities discourage or prohibit delivery of heavy, non-combustible materials in mixed C&D loads which do not generate energy and can damage equipment. Further, landfill capacity in Massachusetts is rapidly depleting, leading to extremely high disposal tip fees by Arkansas standards (approaching or exceeding \$100 per ton in some areas).

Since 2016, C&D recycling facilities have slowly increased diversion rates of the C&D materials they receive, reaching 25 percent in 2019. MassDEP is current exploring the efficacy of setting a higher minimum diversion requirement.

Table 4-7 summarizes these strategies and tools, and further comments on the cost imposed both on city governments and/or the districts. This table also identifies the implementing entity that would be likely in Northwest Arkansas, based on the configuration of solid waste management in the state and region.



# C&D RECOVERY POTENTIAL

Table 4-7 Summary of C&D Diversion Strategies

Strategy (from lowest to highest regulatory)	Cost to City/District Governments	Cost to Industry	Best Implemented by	Notes
Outreach and Education	Low	Low	City, District, State	C&D recycling and reuse education should be evident at all levels of government
Technical Assistance	Med	Low	District	Districts are well positioned to serve this role
Recycled Content Requirements	Low-Med	Low-Med	City	Stringent requirements could increase the cost of publicly funded projects
Planning Requirements	Low	Low	City	Enforcement can occur through the building and zoning department during the permitting process
Reporting Requirements	Low	Low	City, District	Reporting is a first step towards understanding current practices and developing a basis for diversion requirements
Diversion Requirements	Med	Med	City, District	Diversion requirements are often implemented in regions with more robust C&D processing capacity
Deconstruction Requirements	Low	Med-High	City	Deconstruction requirements could spur expansion of local salvage business or new market entrants
Recycling Deposits for Developers	Med	Med	City	Deposit programs are a form of enforcement or incentive to meet diversion requirements
Economic Incentives for Haulers	Med	Low-Med	District	Districts maintain hauler licensure obligation and would be logical administrator for hauler incentives. Franchise fees would be passed through to customers.
Processing Requirements/ Landfill Ban	Med	High	State	C&D recycling facilities are operating in other Arkansas markets (Little Rock)
Market Development	Med-High	Med	State, District	Must have solid basis for new business investment in the region

## 4.5.2 MIXED C&D RECYCLING INFRASTRUCTURE

Results from this study revealed both interest in and potential for increasing C&D landfill diversion rates. As the region continues to grow, the Districts in Northwest Arkansas may play a key role in fostering the infrastructure necessary to support reduction policies and programs. Northwest Arkansas can begin establishing expectations that C&D recycling and diversion plans as appropriate and to begin laying the groundwork for future enhancements to C&D recycling in the region.

## C&D RECOVERY POTENTIAL

It was reported by several regional stakeholders and subsequently verified by the Project Team that at least one private entity is investing in C&D processing in Northwest Arkansas. It would be a highly favorable development for Northwest Arkansas to attract an experienced facility operator that knows the industry and has extensive equipment and operations management experience.

C&D processing has found a foothold in the Little Rock market, as well as others in the Midwest. Discussions were held with a C&D recycler in the St. Louis region to gain insight into infrastructure and considerations. It is useful to understand the level of investment and general processing needs for a C&D recycling facility. Effective C&D recycling requires industrial equipment including truck scale, conveyors, vibratory or trommel screens, magnets, grapples/excavators, air circulation/dust control systems, and rolling equipment to manage the material pre- and post-processing. Some C&D recycling facilities are set up outside, although indoor facilities protect the staffing and expensive equipment from seasonal weather hazards and reduce, or in some cases eliminate, associated air and stormwater management regulations that apply to outdoor operations.

Table 4-8 compiles a list of equipment and capital outlay that were reported to be considered standard for any new facility. The Project Team verified the conceptual building and equipment needs and independently priced the assets. Such a facility would sort and process primarily C&D debris loads that are heavy in aggregate, asphalt and wood products. The capital investment for such a facility was estimated at \$5 to \$7 million, as illustrated in the table (although the cost of land, permitting, and facility design was not considered in the capital cost estimate). It should be noted that in some cases, C&D processors also handle brush, cardboard, soils, drywall, pallets, and potentially other materials.

**Table 4-8 Mixed C&D Recycling Facility Capital Cost Estimate**

Asset	Capital Cost
Facility (35,000-40,000 sq.ft.)	\$1,500,000
Scale	\$100,000
Crusher	\$850,000
Shaker Plant or Trommel Screen	\$750,000
Conveyors	\$400,000
Magnet	\$75,000
Large Excavator	\$400,000
Small Excavator or Skid Steer	\$30,000
Wheel Loader	\$350,000
Layout & Design	\$50,000
Grinder (wood waste)	\$750,000
<b>Total</b>	<b>\$5,255,000</b>

Source: Facility and equipment needs provided by a private C&D recycling facility operator. Capital cost estimates obtained through independent research.

It should be noted that any facility capable of sorting mixed C&D debris would require significant acreage in an industrially zoned area. It was reported by the City of Springdale that opportunity zones exist within the City to host this type of facility.

Although it was beyond the scope of this effort to project the likely processing cost of a C&D recycling facility, this question can be informed by other facilities around the country with which the project team

## C&D RECOVERY POTENTIAL

---

has familiarity. Generally, the better a C&D recycling facility can pre-filter its inbound deliveries to maximize the recyclable material content, the more attractive a tip fee they can offer. Tip fees for highly recyclable loads may be competitive with landfill disposal. However, for highly mixed C&D loads where no effort was made by the builder to segregate targeted materials, tip fees would be expected to be higher than landfill tipping fees in Northwest Arkansas.

### 4.6 C&D DIVERSION RECOMMENDATIONS

#### 4.6.1 INITIAL NEEDS

This chapter has served primarily to identify the amount of C&D debris being disposed via landfill, and to identify the strategies that could be implemented to increase C&D recycling and reuse. However, there are still significant gaps that inhibit the immediate ability of the region to finalize various details. In the near term, the region should undertake the following initial steps:

- ◆ **Designate C&D Stakeholder Advisory Group.** The community that will be impacted by C&D recycling initiatives is large and diverse. It includes landfill managers, private haulers who currently collect C&D debris, city and district waste management staff, city building and zoning department staff, and a vast network of builders, roofers and other contractors that perform construction, demolition, and renovation services. Because C&D recycling initiatives may increase the current cost of construction projects, it may be useful to include local chambers of commerce to provide guidance on how to scale up a program most effectively.
- ◆ **Compile City- and Region-specific Building Permit Data.** To formulate C&D recycling planning and reporting requirements, it will be necessary to gain a detailed understanding of the building permit processes and volume of permits occurring in the region. A review should be undertaken to identify the types of projects, project value, project square footage, and classification (i.e., new construction, demolition, roofing, etc.) within cities and counties in the region (i.e., any entity responsible for issuing building permits).
- ◆ **Compile C&D Disposal by County of Origin from Disposal Facility Reports:** Current state-mandated landfill reporting provides some data about the overall quantities of material disposed from each county. Further, the Eco Vista landfill operates a Class 4 landfill cell that accepts C&D debris, which helps focus in on this waste stream. However, C&D debris is also coming through transfer stations in the region, which would be mixed with MSW and deposited in the Eco Vista Class 1 cell.

The outcome of these steps will inform the development of more specific recommendations for increasing C&D diversion in Northwest Arkansas.

#### 4.6.2 EXPAND SWD ROLE IN C&D DIVERSION ORGANIZATION

Once additional information is known about the baseline for C&D generation and recovery, the Boston Mountain SWD is well positioned to expand its role and focus to increase C&D diversion.

- ◆ **Establish a Budget, Resource Allocation, and Funding for C&D Recycling:** A centrally managed initiative to baseline and increase C&D diversion in the region will require a financial commitment. Determination of the size and cost of this organization, as well as the funding source(s), is an important first step.
- ◆ **Set Diversion Goals:** Establishing the baseline and setting diversion goals for the region for municipal and county leaders to adopt is an opportunity to set expectations for C&D debris generators, builders, hauling companies, and other stakeholders in the region. These goals could start out as voluntary but shift to more formal targets in the future as C&D recycling evolves.
- ◆ **Implement Reporting and Measurement System:** Based on disposal records available through permitted solid waste facilities, and on the compilation of regional building permits data, the region should annually compile information about C&D debris generation, disposal, and diversion, linking to

building permit data. Developing a reporting system to be managed by the District would provide data tracking, and an enforcing mechanism if established policies warrant.

- ◆ **Establish SWMD Technical Assistance Capabilities:** While the specific roles will require input and validation from the cities, the SWD's C&D diversion team could potentially be charged with:
  - ◆ Performing routine outreach to the community in business forums, governmental meetings, and through other means and media.
  - ◆ Offering technical expertise to local governments and the private building and recycling community to advance C&D recycling, reuse, and diversion throughout the region.
  - ◆ Compiling a database of C&D debris salvage, reuse, and recycling businesses in and around the region and connecting builders and developers with these businesses.
  - ◆ Tracking and publicizing recycled content building products and related specifications for use in public sector development projects.
  - ◆ Developing one or more model planning and reporting templates for adoption by local governments as part of the building permit process.

### 4.6.3 IMPLEMENT ORDINANCE AND POLICY CHANGES

Cities and counties in the region would both participate in the development of, and benefit from the release of guidance for enhancing C&D diversion. Incorporated cities throughout the Boston Mountain SWD would be able to adopt recommended actions to support C&D recycling. Such actions include:

- ◆ Support the SWD to assure availability of critical C&D generation, recycling, disposal and building activity information.
- ◆ Establish or enhance recycled content requirements for publicly funded projects.
- ◆ Implement planning and reporting requirements as part of the permitting process.
- ◆ Establish city-specific diversion requirements, deposit systems, and other performance requirements for C&D waste generators over a longer period.

Individual cities would likely demand some flexibility in setting thresholds for the imposition of planning, reporting and performance requirements, so the resulting program would need to provide options so that cities could come on board at their preferred pace.

This page intentionally left blank.

## 5. POTENTIAL RECOVERY SCENARIOS

---

### 5.1 INTRODUCTION

The Northwest Arkansas region has many options to increase diversion of MSW and C&D materials from landfill disposal. Previous sections provided detailed background and discussion of these options across the three-county region.

Potential options for the management of recycling, organics, and C&D debris in Northwest Arkansas were presented to regional stakeholders via webinar on November 19, 2020. A total of 43 stakeholders, including local and County government elected officials as well as various sanitation and sustainability staff, were included in the briefing. Additionally, a survey was submitted to all stakeholders. Results from this survey, as well as a list of attendees, can be found in Appendix E. The feedback received from this survey have been incorporated into the development of scenarios for further consideration.

This section attempts to concisely summarize viable scenarios for increasing diversion rates and sustainably managing materials in Northwest Arkansas region. Note that some of the scenarios are exclusive (i.e., only one but not the other could be followed), while other scenarios are complimentary and could be pursued in sequentially or in parallel with other scenarios. The selection of an optimal set of scenarios will require ongoing communication and collaboration among regional stakeholders.

A summary of potential recovery scenarios is shown in Table 5-1. The remaining subsections in this chapter elaborate on the strategies, supporting actions, and recommendations associated with each of the main study components:

- ◆ Recycling Recovery, including:
  - ◆ Regional recycling standards (RS),
  - ◆ Recyclables processing capacity expansion (RP),
  - ◆ Regional recycling collection (RC),
- ◆ Organics Recovery (Org), and
- ◆ C&D Recovery (CD).

Each scenario is summarized in a table that includes a description of the scenario, enumerates a set of supporting actions that might be undertaken to advance the scenario, and comments on the outcome if that scenario were completed. The summary tables also identify the party or parties that would be expected to lead each supporting action. Finally, each section includes a list of other recommendations to be considered as the region progresses.

# POTENTIAL RECOVERY SCENARIOS

Table 5-1 Scenario Summary

System Element	Scenario	Description
Regional Recycling Standards (RS)		<b>Status Quo</b>
	RS-1	Leave the development of recycling standards to individual municipalities, counties, businesses and institutions, and the haulers that serve them.
		<b>Designate SWMDs to Develop Standards</b>
	RS-2	Assign development of recycling standards and recycling branding to the SWMDs as an expansion of their current responsibilities.
		<b>Designate Development of Standards to a Regional Authority</b>
	RS-3	Assign development of recycling standards and recycling branding to a regional authority spanning both SWMDs.
Recyclables Processing Capacity Expansion (RP)		<b>Status Quo</b>
	RP-1	Cities, counties, businesses and institutions continue arranging for recyclables processing through existing means.
		<b>Designate SWMDs individually to manage regional recyclables processing</b>
	RP-2	Create a formal framework for SWMDs to expand their current responsibilities to include management of recyclables processing within the District.
		<b>Create a single regional entity to manage regional recyclables processing</b>
	RP-3	Establish and designate regional recyclables processing to a single entity (with the potential to take on other aspects of regional recycling, i.e., collection, etc.)
Regional Recycling Collection (RC)		<b>Migrate to Regional Single Stream Collection</b>
	RC-1	To improve worker safety, maximize collection efficiency, and maximize recycling capture, maintain existing single stream services and migrate from curb sort to single stream over time.
		<b>Migrate to Regional Dual Stream Collection</b>
	RC-2	To balance issues of contamination, collection efficiency and worker safety, migrate current curbside collection programs to dual stream.
		<b>Expand Recycling Drop-off Access in Madison County</b>
	RC-3	Add temporary or permanent recycling drop-off access to other communities beyond Huntsville.
		<b>Expand Household Hazardous Waste Disposal Access</b>
	RC-4	Expand access to HHW disposal across the Northwest Arkansas Region.
Organics Diversion (Org)		<b>New Regional Organics Program</b>
	Org-1	Develop new three-county regional organics processing facility with technology to process food and other compostable waste utilizing a multi-phased approach.
		<b>Expand Existing Processing Facilities and Programs</b>
	Org-2	Expand existing facilities to ensure each SWMD has at least one facility with the capacity and technology to process food and other compostable waste.
C&D Diversion (CD)		<b>Implement Voluntary C&amp;D Diversion Programs</b>
	CD-1	Establish a regional technical assistance provider to expand outreach, recruit private sector processing, and establish a network of builders, haulers and other stakeholders to evolve C&D recycling over time.
		<b>Implement Mild Regulatory Requirements</b>
	CD-2	Implement requirements and non-mandatory C&D recycling goals to grow awareness of C&D recycling in the region without imposing significant additional cost on the industry.
		<b>Implement Aggressive Regulatory Requirements</b>
	CD-3	Establish requirements and financial incentives for diversion of C&D debris to recycling and reuse.
		<b>Develop Regional C&amp;D Processing Infrastructure</b>
	CD-4	Establish requirements and financial incentives for diversion of C&D debris to recycling and reuse.



## 5.2 RECYCLING RECOVERY

This study identified the challenges associated with migrating many different residential recycling programs towards a more standardized regional system, and also developing additional infrastructure to process recyclables. More coordinated regional management and expanding processing capacity are both tied to the way in which cities, counties and the Districts choose to cooperate and collaborate. The issues of “recycling standardization” and “recyclables processing capacity expansion” are therefore intertwined.

The following subsections focus on recycling standardization and expanding processing capacity, as well as on the identified need for greater access to drop-off recycling and HHW diversion. Finally, some thoughts are provided about longer-term considerations that will need to be undertaken should any cities convert from their current recycling collection method to a new collection method that could improve capture rates and capitalize on any new regional processing infrastructure. *It is recognized that Fayetteville, Siloam Springs, and potentially other cities that currently curb-sort their residential recyclables, are not interested in changing to a more commingled collection system in the foreseeable future, and nothing in this section is intended to suggest that any city should be forced or expected to change their current system.*

### 5.2.1 RECYCLING STANDARDS (RS)

Available data and feedback indicate that there is interest across the region to have more uniform recycling programs and standards, as shown in Table 5-2. Standardization would be expected to improve recycling performance simply by eliminating confusion as residents move within the region, and would allow commercial business, schools, and other institutions to expand recycling opportunities with less chance for conflicting messaging about recycling.

**Table 5-2 Key Findings: Recycling Standardization (RS)**

- Specific materials targeted in residential recycling programs vary across the region.
- Recycling messaging is distributed by and among multiple public and private sector entities, creating some level of messaging inconsistency across the region.
- Regional focus groups and surveys have identified a desire to have greater consistency in recycling programs.

Table 5-3 summarizes the options of maintaining the status quo and only addressing regional standardization minimally by existing public sector organizations.

# POTENTIAL RECOVERY SCENARIOS

**Table 5-3 Scenario RS-1: Maintain Status Quo for Recycling Standards**

<b>Scenario Description</b>	<i>Leave the development of recycling standards to individual municipalities, counties, businesses and institutions, and the haulers that serve them.</i>	
<b>Supporting Actions</b>		<b>Responsible Party</b>
1)	Convene regional stakeholders routinely to collaborate and standardize where possible.	NWA Council
2)	Track recycled material markets and pricing.	Districts
3)	Attend one regional and one national recycling conference each year, and establish an annual training plan to stay abreast of market trends within the industry.	Cities/Districts
4)	Develop District-specific recycling specifications and contractual templates for inclusion in collection and processing contracts.	Districts
5)	Consult independent industry sources, such as SWANA, The Recycling Partnership, and ISRI to develop recycling standards.	Cities/Districts
<b>Outcomes</b>		
	No initial cost incurred by stakeholders, but may lead to higher recycling program expenses over time.	
	Lowest impact to recycling behavior changes.	

Alternatively, the region may designate the responsibility for establishing recycling standards to the Districts, capitalizing on their existing expertise, and slightly expanding current District responsibilities. This scenario is summarized in Table 5-4.

# POTENTIAL RECOVERY SCENARIOS

**Table 5-4 Scenario RS-2: Designate Districts to Develop Recycling Standards**

<b>Scenario Description</b>	<i>Assign development of recycling standards and recycling branding to the Districts as an expansion of their current responsibilities.</i>	
<b>Supporting Actions</b>		<b>Responsible Party</b>
1)	Inventory current recycling program materials and set-out requirements by District.	Districts
2)	Develop District-specific recycling program outreach and branding.	Districts/ NWA Council
3)	Verify support and funding from cities to support and adopt District recycling standards.	Cities
4)	Develop District-specific recycling specifications and contractual templates for inclusion in collection and processing contracts.	Districts
5)	Extend outreach to businesses and institutions at the District level to enhance participation.	Districts
6)	Conduct a waste composition study (WCS) for the region to determining recycling (and organics recovery) potential.	Districts
<b>Outcomes</b>	<p>Some incremental cost could be incurred by the Districts to take on this responsibility.</p> <p>Leverages existing organizations with foundation of expertise and funding sources.</p>	

A more aggressive approach to developing regional standards would be to establish a central managing organization spanning the three-county region. This scenario is summarized in Table 5-5.

**Table 5-5 Scenario RS-3: Designate Development of Standards to a Regional Authority**

<b>Scenario Description</b>	<i>Assign development of recycling standards and recycling branding to a regional authority spanning both Districts.</i>	
<b>Supporting Actions</b>		<b>Responsible Party</b>
1)	Inventory current recycling program materials and set-out requirements for the NWA region.	Regional Manager
2)	Develop NWA regional recycling program outreach and branding.	Regional Manager
3)	Verify support and funding from NWA stakeholders to migrate to regional standards.	Cities/ Districts
4)	Develop regional recycling specifications and contractual templates for inclusion in collection and processing contracts.	Regional Manager
5)	Extend outreach to businesses and institutions across the NWA region to enhance participation.	Regional Manager
<b>Outcomes</b>	<p>Maximizes regional uniformity of recycling standards.</p>	

# POTENTIAL RECOVERY SCENARIOS

Requires current stakeholders to defer some responsibility for recycling to a regional entity, potentially reducing local recycling program control.

Note that the term “Regional Manager” is intended to denote an unspecified organization to centrally manage recycling in the region, potentially to span not only development of standards but also to coordinate the expansion of processing capacity (discussed in the next subsection). Several options for creating a Regional Manager organization have been identified by stakeholders. These include:

- ◆ Establishing a **new Regional Authority** with appropriate support, funding, and staffing,
- ◆ **Combining the Boston Mountain and Benton County Districts** into a single regional District to leverage their state-mandated status and existing organizational expertise, and
- ◆ **Selecting an existing organization and bestowing authority** to serve as the Regional Manager.

It was noted by stakeholders that the **Northwest Arkansas Regional Planning Commission** could be a vehicle for convening the boards of the two Districts on a once or twice a year basis to initiate discussions about formation of the best Regional Manager. This would involve one or more public meetings and a new use for this Commission that has proven a way in the past for individual organizations and governments to come together to educate, establish goals and plan. Moreover, the Regional Planning Commission has a history of convening local governments in ways outside of the Commission’s traditional work areas such as when it worked extensively on the development of a regionwide wayfinding system, and when it oversaw the creation of a Northwest Arkansas bicycle/pedestrian master plan, including the coordination of meetings about protecting open spaces.

Further, the **Northwest Arkansas Council**, a private nonprofit organization with recycling-related goals in its strategic plan, has expressed a willingness to be a convener of the larger group of recycling stakeholders on a more regular basis and could facilitate the establishment of a Regional Manager. Historically, the NWA Council has focused on the private sector, but has been successful asking governments to work together more often. The NWA Council can encourage and support a regional, governmental-led process, but does not seek to manage or otherwise be the lead agency for regional recycling initiatives.

## 5.2.2 REGIONAL RECYCLABLES PROCESSING (RP)

Table 5-6 summarizes the challenges associated with recyclables processing in Northwest Arkansas.

**Table 5-6 Key Findings: Regional Management of Recyclables Processing (RP)**

- There is not currently sufficient processing capacity in the region to accommodate the volume of recyclables generated, nor absorb the high growth in generation.
- If recyclables processing capacity is going to be increased, it has historically been more economical to do so on a larger, centralized scale.
- Closed Loop Partners is attempting to bring to market cost-effective mini-MRF technology for local governments in regions that don’t generate or can’t commit larger processing volumes.
- New/expanded processing capacity will require long-term tonnage commitments from suppliers.
- Management of tonnage commitments and associated financial support for processing will be required of one or more managing organizations.

## POTENTIAL RECOVERY SCENARIOS

It is noted previously in this analysis that recycling is currently functioning throughout the region with many parties engaged in collecting, processing, and marketing recyclables. Table 5-7 summarizes the scenario of maintaining this status quo.

**Table 5-7 Scenario RP-1: Maintain Status Quo (Leave Processing to Market Forces)**

<b>Scenario Description</b>	<i>Let cities, counties, businesses and institutions continue arranging for recyclables processing through existing means.</i>	
<b>Supporting Actions</b>		<b>Responsible Party</b>
1)	Pursue multi-municipal partnerships where possible to increase recyclables volume when seeking processing services.	Cities
2)	Take steps such as direct feedback programs (i.e., container monitoring) to reduce contamination and maintain cleanliness of curbside recyclables.	Cities
3)	Encourage municipalities to separate recyclables processing terms from other services to gain an understanding of the current costs and market dynamics.	Districts/Cities
4)	Monitor and evaluate emerging vendors of mini-MRF technology, targeting generators of 15,000 tpy or less.	Districts/Cities
5)	Monitor and track other recycling industry and market developments.	Districts/Cities
<b>Outcomes</b>	<p>Minimizes behavior changes among residents and businesses.</p> <p>No immediate cost impact, but may increase the risk of future pricing shocks with low transparency to recycling program manager.</p> <p>Incremental growth in diversion in line with population growth. May be impacted positively or negatively by macro changes in recycling and/or private hauling market.</p>	

Alternatively, it may be appropriate for the Districts to take on a centralized role in expanding processing capacity. This has the immediate benefit of increasing the available volume of recyclables to achieve a larger scale of any processing solution that at least spans each district. Table 5-8 summarizes this scenario. (As described throughout this study, it should be noted that there are other benefits to the Districts to collaborate beyond the expansion of regional processing infrastructure.)

# POTENTIAL RECOVERY SCENARIOS

**Table 5-8 Scenario RP-2: Designate Districts to Expand Processing Capacity**

<b>Scenario Description</b>	<i>Create a formal framework for Districts to expand their current responsibilities to include management of recyclables processing within the District.</i>	
<b>Supporting Actions</b>		<b>Responsible Party</b>
1)	Establish District budgets and revenue mechanisms to support added responsibilities.	Districts
2)	Enhance professional staffing to acquire the expertise needed for District-level management of recyclables processing.	Districts
3)	Inventory current recyclables processing contracts and define available volume and type of processing needed to serve each District.	Districts
4)	Coordinate with Districts to align future collection contract terms to enable seamless and timely migration to any future regional processing system.	Cities
5)	Verify municipal participation in District-level program and secure commitments of recyclables from cities, counties, businesses, and institutions in each District.	Districts/Cities
6)	Establish programs, policies and expectations imposed on individual suppliers to minimize contamination and maximize yields (e.g., visual inspections, single-stream composition audits, direct feedback programs.)	Districts/Cities
7)	Determine appropriate procurement process and contractual terms for processing (or transfer and long haul) at the District level.	Districts
8)	Initiate procurement processes to develop MRF or otherwise secure required capacity for committed District recyclables.	Districts
<b>Outcomes</b>		
	Leverages District-level recycling tonnages to secure more cost-effective processing infrastructure.	
	Two (or more) new* processing facilities estimated to be 40% more costly than a single regional facility (with processing cost of ~\$97/ton) (See Sec 2.6.3 and Exhibit 2-1 for assumptions and cost estimates.)	
	When paired with optimization of recycling collection, may double recycling of District-level fiber and containers.	
	Potentially enables expansion of single-stream recycling within businesses and institutions by reducing processing costs.	

*\* could also include expanding or retrofitting the single existing facility*

A final, more aggressive option to maximize the available volume of recyclables and increase leverage in the development of processing capacity is to establish a single regional entity to secure processing capacity from as much committed tonnage as possible. This scenario is shown in Table 5-9.



# POTENTIAL RECOVERY SCENARIOS

**Table 5-9 Scenario RP-3: Create a Single Regional Entity to Expand Processing Capacity**

Scenario Description	<i>Establish and designate regional recyclables processing to a single entity.</i>	
<b>Supporting Actions</b>		<b>Responsible Party</b>
	1) Evaluate consolidation of the two Districts into a single District, as well as other regional organizations capable of taking on regional recycling, to determine best course of action for a regional manager. This could include formal agreements between existing organizations rather than establishing a new entity; or combining existing entities.	Districts/ Cities
	2) Establish regional manager budgets and revenue mechanisms to support the regional recyclables processing mission.	Regional Manager
	3) Enhance professional staffing to acquire the expertise needed for regional management of recyclables processing.	Regional Manager
	4) Inventory current recyclables processing contracts and define available volume and type of processing needed to serve the NWA region.	Regional Manager
	5) Verify municipal participation in a regional program and secure commitments of recyclables from cities, counties, businesses, and institutions in each District. Secure commitments of recyclables from cities, counties, businesses, and institutions in the NWA region.	Regional Manager/ Districts/Cities
	6) Establish programs, policies and expectations imposed on individual suppliers to minimize contamination and maximize yields (e.g., visual inspections, single-stream composition audits, direct feedback programs.)	Regional Manager/ Cities
	7) Determine appropriate procurement process and contractual terms for processing (or transfer and long haul) within the NWA region.	Districts
	8) Initiate procurement processes to develop MRF or otherwise secure required capacity for committed regional recyclables.	Districts
<b>Outcomes</b>	<p>Leverages District-level recycling tonnages to secure the most cost-effective processing infrastructure.</p> <p>One large regional processing facility estimated to achieve processing costs below \$60 per ton. (See Sec 2.6.3 and Exhibit 2-1 for assumptions and cost estimates.)</p> <p>When paired with optimization of recycling collection, may double recycling of District-level fiber and containers.</p> <p>More fully enables expansion of single-stream recycling within businesses and institutions by reducing processing costs.</p>	

*\* could also include expanding or retrofitting the single existing facility*

### 5.2.3 DROP-OFF CONVENIENCE CENTERS (RC)

While recycling access is generally high in Washington County, expanded access to recycling was identified as a need in Madison County. Table 5-10 summarizes the prospect of increasing access to drop-off recycling in Madison County.

# POTENTIAL RECOVERY SCENARIOS

**Table 5-10 Scenario RC-3: Expand Recycling Drop-off Access in Madison County**

Scenario Description	<i>Add temporary or permanent recycling drop-off access to other communities beyond Huntsville.</i>	
<b>Supporting Actions</b>		<b>Responsible Party</b>
1)	Engage municipal leadership to evaluate mobile or permanent drop-off sites in St. Paul and Hindsville.	St. Paul/ Hindsville
2)	Identify capital and operating budgets for new service location(s) and establish sustainable revenue mechanisms to cover costs.	Boston Mountain SWD/St. Paul/Hindsville
3)	Advertise drop-off facility expansion to new areas.	Boston Mountain SWD/St. Paul/ Hindsville
4)	Utilize surveys at the current facility to map out usage patterns and guide site selection for any new facility.	Boston Mountain SWD/St. Paul/ Hindsville
5)	Procure and implement the service.	Boston Mountain SWD
<b>Outcomes</b>		
	Expands regional recycling awareness and access.	
	Marginal operating cost increase for temporary sites.	
	Potential for increased diversion of 50 tpy of fiber and container recyclables.	

## 5.2.4 HHW SERVICES (RC)

While HHW diversion and disposal options exist in the region, opportunities exist to increase access to these services. Table 5-11 presents a consideration for expanding HHW disposal access through special events, a mobile collection program, or establishment of one or more new permanent sites.

**Table 5-11 Scenario RC-4: Expand HHW Disposal Access**

Scenario Description	<i>Expand access to HHW disposal across the Northwest Arkansas Region.</i>	
<b>Supporting Actions</b>		<b>Responsible Party</b>
1)	Evaluate strategies for special HHW collection events in Benton County SWD to supplement Convenience Center access.	Benton County SWD
2)	Evaluate strategies for special HHW collection events in Boston Mountain SWD to supplement sites in Prairie Grove and Huntsville.	Boston Mountain SWD
3)	Create a mobile HHW collection program.	Districts
4)	Offer technical assistance and grant funding to establish permanent collection locations in additional cities.	Districts
<b>Outcomes</b>		
	Removal of additional HHW materials from landfill disposal where substances can create long-term pollution risks.	
	\$75,000 to set up a mobile program in conjunction with existing permanent site.	

### 5.2.5 RECYCLABLES COLLECTION (RC)

It is not a requirement for regionalizing recycling to convert all cities to the same type of curbside recycling collection. As reported previously in this document, some communities are not interested in making changes. However, as a regional program advances, and assuming single-stream curbside recycling is proven to be effective in communities where this is the current standard, single-stream collection has been shown to capture larger volumes of recyclables. Increased volume would benefit a regional MRF.

To the extent single-stream is optimized where currently installed, curb sort communities may eventually follow suit. Cities with curb sort that eventually opt for single-stream will have to undertake any changes in a manner that is acceptable to their residential customers and elected officials. These changes take time and therefore collection system modifications will likely have the longest duration to reach regional single-stream collection.

Table 5-12 summarizes these circumstances, but also points out generic benefits of more automated forms of recycling collection.

**Table 5-12 Key Findings: Recyclables Collection (RC)**

- Current recycling collection methods in NWA include drop-off, curb sort, and curbside single stream.
- Minimizing contamination is important to the success of recycling. Communities in the region with curb sort collection, such as Fayetteville, achieve low contamination and may retain their preferred collection methods as long as it suits the needs of their residents. Health and safety considerations, as well as collection efficiency, are driving a move
- towards automated collection over manual collection throughout the collection industry.
- Single stream, cart-based collection has been shown to increase the volume of captured recyclables, albeit with a higher rate of contamination.

Table 5-13 summarizes the considerations that would arise in migrating from curb sort (or drop-off only) recycling collection to a single-stream collection system. Because curbside collection is provided at the city level, these changes would require significant lead time and would impact municipal operations for publicly provided collection, and service specifications for contracted collection. Updating contracts to require a different recycling collection service would also best be completed as part of a competitive procurement to transition from an expiring contract to a new one.

# POTENTIAL RECOVERY SCENARIOS

**Table 5-13 Scenario RC-1: Migrate to Single-Stream Collection**

<b>Scenario Description</b>	<i>To improve worker safety, maximize collection efficiency, and maximize recycling capture, maintain existing single-stream services, and migrate from curb sort to single-stream over time in areas where curbside collection is economically feasible (i.e., cities and suburbs).</i>	
<b>Supporting Actions</b>		<b>Responsible Party</b>
1)	Survey residents in affected communities to gauge acceptance and develop outreach strategy.	Cities with Curb Sort
2)	Prepare financial projections and establish appropriate rate path to achieve migration with minimal rate shocks to customers.	Cities with Curb Sort
3)	For affected publicly served jurisdictions, develop appropriate vehicle replacement plans, re-routing, staffing, and vehicle maintenance requirements for new collection system.	Cities with Curb Sort
4)	For affected jurisdictions with contracted service, update procurement specifications for new single-stream collection system.	Cities with Curb Sort
5)	Establish policies and programs to monitor and minimize contamination in automated recycling containers (e.g. direct feedback programs), and include associated terms in contractual agreements where applicable.	Cities with Curb Sort
<b>Outcomes</b>	<p>Requires current curb sort communities to significantly change their recycling programs and (potentially) solid waste rates.</p> <p>Studies have found that collection costs decrease on a per-household basis with single stream automated collection.</p> <p>Residential Recycling tonnage to increase between 3,600 and 10,000 tpy*.</p>	

*\*Low end based on current curb sort programs achieving comparable diversion per household as current single stream programs; high end based on optimized performance with regional single stream collection.*

Although it was not extensively evaluated as part of this effort, several stakeholders identified dual-stream recycling collection as a potential means to balance (a) the ability to capture a larger volume of recyclables, (b) more efficient collection, and (c) maintaining cleanliness (i.e., minimizing contamination). There are not currently any dual-stream collection programs in Northwest Arkansas, and realistically it is likely that dual-stream collection would only be considered in tandem with development of dual-stream processing capacity. Nonetheless, Table 5-14 offers a scenario that contemplates conversion to dual-stream collection (starting from either curb sort or from single-stream service.)

# POTENTIAL RECOVERY SCENARIOS

**Table 5-14 Scenario RC-2: Migrate to Regional Dual-Stream Collection**

<b>Scenario Description</b>	<i>To balance issues of contamination, collection efficiency and worker safety, migrate current curb sort and single-stream curbside collection programs to dual-stream.</i>	
<b>Supporting Actions</b>		<b>Responsible Party</b>
1)	Survey residents across the NWA region to gauge acceptance and develop outreach strategy.	Districts/Cities
2)	Prepare financial projections and establish appropriate rate path to achieve migration with minimal rate shocks to customers.	Cities
3)	Evaluate best configuration for dual-stream collection (collection frequency, container types, collection technologies, etc.)	Regional Manager
4)	For publicly-served jurisdictions, develop appropriate vehicle replacement plans, re-routing, staffing, and vehicle maintenance requirements for new collection system.	Cities with Public Collection
5)	For jurisdictions with contracted service, update procurement specifications for new dual-stream collection system.	Cities with Contracted Collection
6)	Establish policies and programs to monitor and minimize contamination (e.g., direct feedback programs), including specifications for contractors.	Regional Manager
<b>Outcomes</b>	<p>Residential Recycling tonnage to increase between 2,500 and 5,000 tpy.</p> <p>Collection cost per households is likely to decrease for cities changing from curb sort, but could increase for cities reverting from single-stream.</p> <p>Imposes operational and financial impacts on every municipality in the region currently providing curbside recycling collection.</p>	

## 5.2.6 SUMMARY RECOMMENDATIONS

Table 5-15 is provided to reiterate some of the supporting actions and to provide supplemental recommendations that would be beneficial under a variety of the scenarios discussed.

# POTENTIAL RECOVERY SCENARIOS

**Table 5-15 Supporting Regional Recycling Recommendations**

Recommendations – Recyclables Processing	Responsible Party
(1) Convene regional stakeholders routinely throughout the process.	Northwest Arkansas Council/ Districts
(2) Develop (collection and) processing specifications for use in all recyclables contracting.	Districts
(3) Engage the existing recyclables processor as a potential solutions provider for the region.	Districts
(4) Perform a baseline recyclables composition study to confirm current single-stream materials value and contamination levels; supplement with routine audits throughout the term of any collection or processing contract.	Single-Stream Cities/ Districts
(5) Select the preferred strategy (number of MRFs, single-stream, sized for residential or both residential/commercial) for expanding regional processing capacity.	All Stakeholders
Recommendations – Recycling Collection	Responsible Party
(1) Develop collection (and processing) specifications for use in all recyclables contracting.	Districts
(2) Pilot test single-stream automated collection on a small number of households; incorporating pre-and post-pilot surveys to monitor acceptance.	Curb Sort Cities
(3) Pilot test direct feedback programs (bin and cart monitoring and tagging) to evaluate the baseline level of contamination in regional recycling programs and use the resulting data to update policies and education.	Single-Stream Cities
(4) Although textile recycling drop-off bins and containers already exist throughout the region, evaluate curbside collection of textiles (which has gained traction in some areas of the country.)	Cities
(5) Evaluate the future potential for establishing solid waste collection franchises to improve reporting, enhance operating health and safety requirements, and give greater control and transparency to government about the services being provided through the franchise.	Cities/ Counties
(6) Survey regional businesses to determine interest in access to a cost-effective single-stream recycling collection service.	Districts
Additional Recommendations	Responsible Party
(1) Continue surveying residents across the region to monitor preferences and interest in accepting changes to improve recycling programs.	Districts/Cities
(2) Enhance data collection and reporting systems to ensure accurate baselines for evaluating future diversion rates and meeting goals.	Districts/Cities
(3) Establish realistic recycling goals and integrate into municipal policies.	Cities
(4) Standardize targeted recyclable materials and create branding/outreach campaigns to span the region.	Districts/Cities



# POTENTIAL RECOVERY SCENARIOS

## 5.3 ORGANICS RECOVERY (ORG)

Research conducted during this analysis revealed several key findings that should be considered when evaluating potential strategies for increasing the recovery rate of organic materials from the waste stream in Northwest Arkansas. These are presented in Table 5-16.

**Table 5-16 Organics Recovery Key Findings (Org)**

- Processing of organic materials varies among jurisdictions.
- Composting of food waste is limited to one facility within the region.
- Business and community support exists for expanding organics recovery opportunities.

Results from this analysis revealed two potential scenarios the BMSWMD may consider to increase recovery of organic materials in the region. As presented in greater detail in Section 3, Table 5-17 presents one scenario for developing a regional organics program, along with and their supporting actions toward implementation.

**Table 5-17 Scenario Org-1: Develop New Regional Organics Program**

<b>Scenario Description</b>	<i>Develop new three-county regional organics processing facility with technology to process food and other compostable waste utilizing a multi-phased approach.</i>	
<b>Supporting Actions</b>		<b>Responsible Party</b>
1) Evaluate private market interest in developing infrastructure for the facility.		TBD
2) Utilize results to determine appropriate ownership and operational structure.		TBD
3) If infrastructure includes public financial investment, determine appropriate procurement process and contractual governing body.		TBD
4) Initiate procurement process and implement supporting policies and programs to ensure adequate feedstock for infrastructure.		TBD
<b>Outcomes</b>		
Diversion potential for Food Waste: 10,000 tpy Diversion potential for Yard Waste: 10,000 tpy One regional organics facility estimated to achieve processing costs below \$25 per ton. (See Sec 3.4.3 for assumptions and cost estimates.) *Based on 30% capture rate. Facility design to allow for growth and additional diversion as program stabilizes.		

Alternatively, existing organics processing capacity could be expanded. This scenario is shown in Table 5-18.

# POTENTIAL RECOVERY SCENARIOS

**Table 5-18 Scenario Org-2: Expand Existing Organics Processing Facilities and Programs**

<b>Scenario Description</b>	<i>Expand existing facilities to ensure each District has at least one facility with the capacity and technology to process food and other compostable waste.</i>	
<b>Supporting Actions</b>		<b>Responsible Party</b>
1)	Evaluate municipal/district interest in expanding capacity of existing facilities to accept food and compostable waste.	Districts/Cities
2)	Utilize results to determine potential funding needs.	Districts/Cities
3)	Identify and secure potential funding sources for infrastructure expansion.	Districts/Cities
4)	Implement supporting policies and programs to ensure adequate feedstock for infrastructure.	Districts/Cities
<b>Outcomes</b>	Diversion tonnage and processing cost per ton are dependent upon facility and extent of expansion.	

Recommended supporting policies and programs are presented in Table 5-19. These will be important for a successful program under either scenario.

# POTENTIAL RECOVERY SCENARIOS

**Table 5-19 Supporting Organic Recovery Recommendations**

<b>Recommendations – Organics Processing</b>	<b>Responsible Party</b>
(1) Develop and distribute policy templates for organic diversion goals.	Districts
(2) Establish organic diversion goals and integrate into municipal policies.	Cities
(3) Develop and distribute policy templates that encourage the use of compostable material and disuse of single use items such as plastic straws.	Districts
(4) Develop Organics Collection Plan to ensure adequate feedstock.	Districts
(5) Integrate composting into education and outreach programming.	Districts/Cities
(6) Perform Waste Composition Study (WCS) to determine capacity requirements for new or expanding facilities.	Districts
(7) Provide grants for municipalities seeking to implement composting pilot projects.	Districts
<b>Recommendations – Organics Collection</b>	<b>Responsible Party</b>
(1) Expand yard waste collection services as a part of all collection contracts and municipal collection programs within the region.	Cities
(2) Incentivize diversion of yard waste by ensuring tip fees are lower than landfill disposal costs.	Facility Owner/Districts
(3) Initiate collection of food waste at drop-off locations maintained by municipalities and districts.	Districts/Cities
(4) Conduct analysis on potential feedstock from area industries to identify capacity need, foster private-sector interest, and identify easy captures.	Districts
(5) Survey regional restaurants and businesses to determine interest in hauling/collection of organic materials.	Districts
(6) Establish a food waste collection pilot program.	Districts/Cities
<b>Additional Recommendations</b>	<b>Responsible Party</b>
(1) Expand regional food pantries and promote food waste reduction through public outreach and education.	Districts/Cities
(2) Enhance data collection and reporting systems to ensure accurate baselines for evaluating future diversion rates and meeting goals.	Districts/Cities
(3) Expand outreach and education programming to support diversion of food waste, compostables and yard waste where applicable.	Districts/Cities

## 5.4 C&D RECOVERY (CD)

The generation, collection and disposal of C&D debris predominantly occurs outside of the purview of county and local governments. Table 5-20 identifies key findings related to diversion of C&D debris from landfill disposal in Northwest Arkansas.

# POTENTIAL RECOVERY SCENARIOS

**Table 5-20 Key Findings: Increasing Diversion of Construction & Demolition Debris (CD)**

- C&D makes up a major fraction of the waste to landfill in the region and a significant percentage of C&D debris is recyclable.
- Management of C&D debris is largely handled outside of the public sector.
- No C&D processing infrastructure exists in the region currently.
- Building/zoning departments can be conduits for establishment of C&D diversion programs.

## 5.4.1 REGULATORY AND POLICY CHANGES

Recognizing that in the near term, most C&D debris will continue to be generated and managed by the private sector, the strategies for increasing diversion of this waste stream will involve regulatory and policy options that create incentives and/or requirements for generators and haulers to recycle and reuse. Table 5-21 presents a scenario that focuses on the establishment of voluntary initiatives. A primary benefit of this as a first step is to establish better data about the generation of C&D debris within NWA.

**Table 5-21 Scenario CD-1: Implement Voluntary C&D Diversion Programs**

<b>Scenario Description</b>	<i>Establish a regional technical assistance provider to expand outreach, recruit private sector processing, and establish a network of builders, haulers and other stakeholders to evolve C&amp;D recycling over time.</i>	
<b>Supporting Actions</b>		<b>Responsible Party</b>
1) Create a regional C&D advisory group including generators, haulers, and potential processors.		Districts/ Developers/ Haulers/ Processors
2) Expand District role to encompass C&D reporting and long-term program development.		Districts
3) Compile building department data and C&D disposal reports for consideration in future program and policy changes.		Cities/ Districts
4) Educate elected officials and the public about the benefits of C&D reuse and recycling.		Districts
5) Publish recycled content requirements for use by builders in the region and integrate these requirements into public sector capital projects.		Cities/ Districts
6) Engage with state agencies and private industry to develop markets for recycled C&D materials.		Cities/ Districts
7) Identify C&D streams that could be delivered to recruit private sector C&D processors to develop merchant infrastructure in the region.		Cities/ Districts
<b>Outcomes</b>		
Immediate, low-cost initiatives targeting a large regional waste stream.		
Moves C&D diversion into regional spotlight.		

A second, more aggressive step to divert C&D debris from landfill would be to implement mild regulatory requirements aimed at improving access to C&D generation and recycling data, and on establishing basic

## POTENTIAL RECOVERY SCENARIOS

requirements on the building community to plan for and report on C&D diversion and recycling. This scenario is shown in Table 5-22.

**Table 5-22 Scenario CD-2: Implement Mild C&D Diversion Regulatory Requirements**

Scenario Description	<i>Implement C&amp;D diversion planning and reporting requirements that stop short of requiring increased diversion.</i>	
<b>Supporting Actions</b>		<b>Responsible Party</b>
1)	Complete the Supporting Actions of Scenario CD-1.	See Scenario CD-1
2)	Set an initial C&D recycling goal for the region based on improved C&D waste generation and building permit data availability	Cities/ Districts
3)	Establish C&D diversion and reuse planning requirements for builders when applying for permits from local governments.	Cities/ Counties
4)	Establish C&D diversion reporting requirements for permitted projects that exceed a minimum size.	Cities/ Counties
<b>Outcomes</b>		
	Establishes explicit expectations for C&D recycling and diversion from landfill.	
	Imposes small incremental expense on businesses to comply with planning and reporting requirements for larger projects.	
	Diversion of 5,000 tpy from landfill at low-end impact.	

Finally, Table 5-23 contains a more aggressive regulatory scenario in which recycling and diversion of C&D debris is required as a condition of permitting construction, renovation, and demolition projects. It should be noted that mandating meaningful recycling of C&D would likely require the availability of mixed C&D processing in the region, which is discussed in the following subsection.

# POTENTIAL RECOVERY SCENARIOS

**Table 5-23 Scenario CD-3: Implement Aggressive C&D Diversion Regulatory Requirements**

<b>Scenario Description</b>	<i>Implement mandatory C&amp;D diversion requirements including diversion targets and recycling fees integrated into building permits.</i>	
<b>Supporting Actions</b>		<b>Responsible Party</b>
1)	Complete the Supporting Actions of Scenario CD-2.	See Scenario CD-2
2)	Develop deconstruction requirements for publicly funded demolition projects and publish such guidance for broader use.	Cities/ Counties
3)	Implement recycling deposits for permitted projects that commits permit holders to seek recycling of C&D materials.	Cities/ Counties
4)	Investigate stakeholder acceptance of franchised collection of C&D debris that imposes recycling and reuse requirements on the franchise haulers.	Cities/ Districts
5)	Develop landfill bans on mixed C&D debris and/or require that all C&D debris be pre-processed prior to disposal.	Cities/ Counties/ Districts
<b>Outcomes</b>	<p>Imposes a larger financial commitment from regional stakeholders to increase C&amp;D recycling.</p> <p>Based on aggressive programs in other areas of the U.S., up to 50% of C&amp;D can be diverted (50,000 tpy+).</p>	

## 5.4.2 REGIONAL PROCESSING

Although it was not identified as a high near-term priority, many of the same benefits of having regional recycling processing capacity would also apply if there were regional C&D processing capacity. Table 5-24 addresses the eventuality of developing C&D processing capacity within the region.

# POTENTIAL RECOVERY SCENARIOS

**Table 5-24 Scenario CD-4: Develop Regional C&D Processing Infrastructure**

<b>Scenario Description</b>	<i>Develop one or more new C&amp;D processing facilities with a requirement that all C&amp;D must be pre-processed before landfill disposal.</i>	
<b>Supporting Actions</b>		<b>Responsible Party</b>
	1) Evaluate private market interest in developing infrastructure for the facility.	TBD
	2) Utilize results to determine appropriate ownership and operational structure.	TBD
	3) If infrastructure includes public financial investment, determine appropriate procurement process and contractual governing body.	TBD
	4) Initiate procurement process and implement supporting policies and programs to ensure adequate feedstock for infrastructure.	TBD
	5) Consider implementing some or all the Supporting Actions of Scenario CD-3.	Cities/ Counties/ Districts
<b>Outcomes</b>	<p>Best combination of performance and cost-effectiveness should the region implement aggressive C&amp;D diversion requirements.</p> <p>C&amp;D processing facility tip fees expected to be higher than landfill tip fees in near future.</p> <p>50% of C&amp;D (or more) can be diverted (50,000 tpy+) at lowest processing cost.</p>	



This page intentionally left blank.

## 6. IMPLEMENTATION CONSIDERATIONS

---

### 6.1 INTRODUCTION

This document contains extensive background and a range of strategies to increase conventional recycling of fiber and containers, expand diversion of food wastes and other organic materials, and ramp up recycling and diversion in the construction and demolition (C&D) debris space. Specific strategies were outlined in the previous section. The range of strategies presented capture the policy, management, operational, regulatory, and performance practices to be implemented in the coming one to ten years if the Northwest Arkansas region intends to divert more materials from landfill and return both recycled commodities, reusable materials, and nutrients to the regional economy.

The development of this document has been a collaborative effort among multiple regional stakeholders, as well as with the consultant Project Team. This engagement was originally conceived as a full-blown planning process, ideally intended to result in a clear and detailed path forward with meaningful consensus from a majority of stakeholders. In practice, consensus was reached on some initiatives, while other initiatives will take more time beyond this process to further advance and refine.

This chapter offers a summary of the critical issues to be solved as forward progress continues with regional recycling, outlines a probable implementation path, and provides guidance on the short-term, medium-term, and long-term nature of implementing the strategies contained herein.

### 6.2 OVERARCHING CONSIDERATIONS

The following overarching issues are highlighted as regional stakeholders evaluate the options and plan the future waste reduction and recycling system in Northwest Arkansas:

- ◆ Regional cooperation,
- ◆ Sensitivity towards standard recycling collection,
- ◆ Widespread acceptance of stronger regulatory measures and higher costs, and
- ◆ Long-term vs. short-term evaluation of diversion over landfill disposal.

These are addressed in more detail below.

#### 6.2.1 REGIONAL COOPERATION

The efficiency and economics of any solid waste processing – whether to recover residential paper, bottles, and cans; recover nutrients or energy from organic wastes; divert construction and demolition materials for reuse or recycling; or even to dispose of wastes in a landfill – are driven by scale. Solid waste facilities capable of higher throughput will generally offer the lowest unit cost. Similarly, contractual commitment of a larger volume of wastes and/or recyclables, and for a longer period rather than a shorter period, will generate the best terms and the lowest costs for the supplier seeking the disposal or processing.

The issue of cooperation spans all aspects of recycling and diversion in Northwest Arkansas: system management, contracting authority, securing a large tonnage commitment, facility development and ownership, recycling system branding, service delivery, etc.

For these reasons, the ability of the region's public sector stakeholders – including the Districts, counties, and cities – to find a workable cooperative framework to aggregate material volumes, and to collectively interact with the private waste and recycling market (whether to build a public facility or contract with a private one), will influence the extent and cost of waste reduction and recycling initiatives.

#### 6.2.2 SENSITIVITY TOWARDS STANDARD RECYCLING COLLECTION

As described in earlier sections, the current split in the region in providing either curb sort or single-stream residential curbside recycling collection stands out as a particularly complex service to standardize over

## IMPLEMENTATION CONSIDERATIONS

---

time. It is expressly acknowledged that cities in the region should provide whichever service their residents prefer, and no city is required to change their current service to participate in a regional recycling program.

As a practical matter, communities that have curb sort recycling enjoy much lower contamination rates, and consequently higher value of recovered recyclables, compared to single-stream communities. However, single-stream communities enjoy lower collection cost, lower risk of injury for collection personnel, and the potential to capture substantially higher volume of recyclables.

It will be critical to find a path that enables the cities in the region to serve their residents in the manner deemed most appropriate by each city, and not to be forced into a regional solution at an inopportune time. This issue will likely have to be solved either by slowing the process towards regional MRF development until a migration to a standardized form of residential curbside recycling collection can be achieved, or else by pursuing regional processing that can reward curb sort systems with higher revenue commitments for cleaner material that requires little to no processing.

### 6.2.3 WIDESPREAD ACCEPTANCE OF STRONGER REGULATORY MEASURES AND HIGHER COSTS

Also related to the notion of regional cooperation will be the ways in which jurisdictions in Northwest Arkansas opt to impose regulatory measures to create more recycling, which will in turn impart higher waste management costs on residential households, commercial businesses, construction companies, and developers. Clearly, when considering new recycling regulations or the conversion to more expensive recycling services, local governments should consider:

- ◆ **Ample lead time** prior to implementing new recycling requirements, so that impacted stakeholders can prepare.
- ◆ **Incremental rate increases**, so that customers do not experience one or more significant rate shocks. Better, escalate rates annually to a small degree and build up operating reserves to support transition.
- ◆ **Focus on a level playing field** for businesses to the extent new regulations are implemented to spur greater waste diversion and recycling.

### 6.2.4 LONG-TERM VS. SHORT-TERM EVALUATION OF DIVERSION OVER LANDFILL

Hundreds, if not thousands, of cities, counties, and regional authorities across the nation have had to transition their waste management systems when their local landfill reached capacity. Based on current efforts by Waste Management to expand the EcoVista landfill capacity to accommodate growth for up to 25 years, Northwest Arkansas may not be impacted by a loss of local landfill space any time soon. However, before the landfill closes, the region should expect to make a significant commitment of additional capital for a new landfill, or else expect heightened operating expense transporting wastes out of the region for distant disposal, or both. Despite the long horizon for the region's only landfill to remain open, it would be wise to consider questions to be answered when local disposal capacity becomes scarce:

- ◆ How many neighbors of the EcoVista landfill are excited about its expansion?
- ◆ How many communities in Northwest Arkansas want a new landfill built within their boundaries so they must contend with odors, groundwater risks, and heavy truck traffic originating from all over the region?
- ◆ How many communities would welcome a new transfer station where dozens or hundreds of trucks would enter, and a smaller number of large semi-trailers would exit every day to export wastes out of the region?
- ◆ How many communities would be willing to host a large-scale, expensive facility to accept the region's waste and process the waste into energy via an industrial process?

## IMPLEMENTATION CONSIDERATIONS

In the experience of numerous jurisdictions across the nation, it has become increasingly difficult – and in many regions both politically, economically, and topographically impossible – to site landfills and other facilities that accept residential and commercial garbage. Establishment of sustainable diversion and recycling programs now will postpone the need for transitioning to a more geographically distant and/or more costly disposal solution for wastes.

### 6.3 IMPLEMENTATION TIMING

Section 5 conveyed a series of potential strategies for five system elements:

- ◆ Regional Recycling Standards (RS),
- ◆ Recyclables Processing Capacity Expansion (RP),
- ◆ Regional Recycling Collection (RC),
- ◆ Organics Diversion (Org), and
- ◆ C&D Diversion (CD).

Within each system element, Section 5 identified multiple strategy options, and enumerated a number of supporting actions if that strategy were pursued.

Once a particular strategy is selected, the actions that support that strategy may be undertaken. Within each strategy, these supporting actions also will follow a logical order. Some actions should be undertaken immediately, while others will follow later. Table 6-1 shows, for each system element, a hypothetical ordering of the supporting actions spread out among short term (1 to 2 years), medium term (3 to 4 years) and long term (5 or more years). In practice, the initiatives identified in this study may progress faster or slower than shown below.

**Table 6-1 Timing and Duration of Supporting Actions for Identified Strategies**

System Element	Scenario	Implementation of Supporting Actions		
		Short Term 1-2 Years	Med. Term 3-4 Years	Long Term 5+ Years
<b>Regional Recycling Standards (RS)</b>	RS-1 Status Quo	All	1,2,3	1,2,3
	RS-2 Districts	All	5	5
	RS-3 Regional Authority	All	5	5
<b>Recyclables Processing Capacity Expansion (RP)</b>	RP-1 Status Quo	All	All	All
	RP-2 Districts	1,2,3,4,5	6,7	7
	RP-3 Regional Authority	1,2,3,4	5,6,7,8	8
<b>Regional Recycling Collection (RC)</b>	RC-1 Drop-off Access	All		
	RC-2 HHW Access	1,2	3,4	
	RC-3 Single Stream	varies	varies	varies
	RC-4 Dual Stream	varies	varies	varies
<b>Organics Diversion (Org)</b>	Org-1 New Regional Program	1	2,3,4	4
	Org-2 Expand Existing Programs	1,2	3,4	3,4
<b>C&amp;D Diversion (CD)</b>	CD-1 Implement Voluntary Programs	All		
	CD-2 Implement Mild Regulations	1	2,3,4	
	CD-3 Implement Aggressive Regulations		1	2,3,4,5
	CD-4 Develop Regional Processing		1,2,5	3,4

# IMPLEMENTATION CONSIDERATIONS

---

A more granular summary of recommended actions and the likely timing is shown in the following sections. Actions are ordered by short-term (1-2 years), medium-term (3-4 years) and long-term (5+ years) in parallel to the preceding table.

## 6.3.1 ONGOING ACTIONS

On an ongoing basis, the region should regularly convene meetings of all regional stakeholders to maintain coordination on recycling and composting initiatives (Scenario RS-1.1). The Northwest Arkansas Council has expressed a willingness and ability to take the lead on these meetings in the near term.

## 6.3.2 ACTIONS IN YEARS 1 AND 2

Actions in the first two years will be focused on organizing the region, improving availability of underlying system data that will be needed to support future direction, and building up technical assistance of the Districts.

### General

- ◆ Establish the Districts as the lead organizations to guide recycling in their respective counties. (RS-2). This includes enhancing their existing technical expertise to expand service to cities, counties, institutions, and businesses. (RP-2.2, CD-1.2).
- ◆ Create a regional recycling brand and outreach materials as a platform to help the region evolve going forward. Include traditional recycling as well as organics diversion and C&D recycling in future outreach and education programming. (RS-2.2)
- ◆ Perform a Waste Composition Study (WCS) as well as a Recycling Composition Study (WCS) and Capture Study for the region to determine actual diversion potential and capacity requirements for any regional or multi-district facility, whether for recyclables, organics, or C&D. (RS-2.6)
- ◆ Cities and the Districts should integrate future recycling and organics system expansion into their financial planning and may wish to program routine revenue escalation to assure a smooth rate path for customers. (RP-3.2)

### Regional Recycling

- ◆ With guidance from the Districts, cities that contract for collection services should align the terms of their contracts to maximize the available tonnage at such time as new processing capacity is developed in the region. (RP-2.4)
- ◆ Cities with curbside programs should plan to conduct material composition audits to baseline the commodity mix, material value, and contamination level of their recycling program. (RP-1.2)
- ◆ Districts and cities should engage Marck Industries in more detailed conversations about expanding capacity for mixed recyclables processing, and to develop fair and transparent terms for current and future direct processing agreements.
- ◆ Recruit a city with single-stream recycling to conduct a pilot test cart monitoring program to measure current contamination and set-out behaviors, and to inform the regional education program on messaging that will improve regional recycling. (RP-2.3)
- ◆ The Boston Mountain SWMD should undertake the follow-up surveying and related plans to verify the need and location for an additional drop-off location in Madison County. (RC-3)

### Organics

- ◆ Establish regional or local organic diversion goals addressing yard waste, food waste and organic compostables, and integrate into District mandates.
- ◆ Survey regional restaurants and large facility businesses to determine interest in private hauling/collection of organic materials.

## IMPLEMENTATION CONSIDERATIONS

---

- ◆ Initiate collection of organic materials at drop-off locations maintained by the municipalities and Districts.

### C&D

- ◆ Under the leadership of the Districts, establish a C&D stakeholder Advisory Group (which could be integrated into the regular regional stakeholder meetings (CD-1.1)
- ◆ Encourage private C&D processors to enter the Northwest Arkansas regional market on a merchant basis.
- ◆ The Districts should compile city- and region-specific building permit data to better understand the availability of information, resources, permit requirements, and policies in effect that could be leveraged in preparation for developing regional C&D diversion plans. (CD-1.3)
- ◆ With input from the C&D Advisory Group, publish recycled content requirements to be integrated into public sector capital projects. (CD-1.5)

### 6.3.3 ACTIONS IN YEARS 3 AND 4

These actions are dependent upon the outcomes of the Actions completed in Section 6.3.2.

#### Regional Recycling

- ◆ Revisit municipal participation in a regional program and secure commitments of recyclables from cities, counties, businesses, and institutions in each District. (RP-3.6)
- ◆ Establish programs, policies and expectations imposed on individual suppliers to minimize contamination and maximize yields. (RP-3.7)
- ◆ Determine appropriate procurement process and contractual terms for processing (or transfer and long haul) within the NWA region. (RP-3.8)
- ◆ Any community considering a change in its collection system should revisit collection economics based on the recycling performance data compiled by the Districts in prior years.

#### Organics

- ◆ Conduct detailed analysis of feedstock potential from area industries to determine potential diversion numbers and ensure the collection of enough material to warrant an organics processing facility.
- ◆ Expand yard waste collection services as a part of collection contracts to all municipalities within the region.
- ◆ Consider engaging community stakeholders to determine a best location to establish a food waste collection pilot program.
- ◆ Work with Fayetteville to upgrade/expand composting, or else site a secondary site.

### C&D

- ◆ Implement mild C&D diversion regulatory requirements. (CD-2)
- ◆ Evaluate private market interest in developing infrastructure for the facility and utilize results to determine appropriate ownership and operational structure if appropriate. (CD-4.1, 4.2)

### 6.3.4 ACTIONS IN YEARS 5+

Development of new regional facilities and establishment of aggressive regulations associated with C&D recycling are expected to have the longest horizon for implementation in the region.

#### Regional Recycling

- ◆ Initiate procurement process to develop a regional recycling facility. (RP-3.9)

## **IMPLEMENTATION CONSIDERATIONS**

---

- ◆ Curb sort cities should monitor the performance of single-stream recycling systems and may wish to revisit the migration to single-stream collection to maximize recycled volumes and capitalize on a regional MRF at this time.

### **Organics**

- ◆ Develop a regional organics facility (if necessary), ideally near the Benton/Washington County border to be centrally located and capable of accepting organics from generators across the region.

### **C&D**

- ◆ Implement aggressive C&D diversion regulatory requirements. (CD-3)
- ◆ Revisit the C&D disposal and processing market dynamics to evaluate whether a regional processing facility has gained traction and undertake appropriate planning and procurements steps if appropriate. (CD-4.3, 4.4, 4.5)

## **6.4 NEXT STEPS**

Northwest Arkansas is a fast-growing region with effective waste management systems and a vibrant, world class business community. Led by the Boston Mountain Solid Waste Management District and the Benton County Solid Waste Management District (and with funding support from the Northwest Arkansas Council), this waste reduction and recycling initiative compiled extensive system data, involved key stakeholders in the municipal, institutional, and commercial sectors; investigated successful practices and solution from other regions; and hypothesized what regional recyclables processing, organics processing, and C&D recycling might look like in time.

This feasibility analysis should be distributed to participating stakeholders once adopted by respective leadership/boards. The NWA Districts should commence planning regular stakeholder meetings to move forward with discussion and undertaking agreed-upon Year 1-2 recommendations to launch the longer-term objectives.



---

# APPENDIX A

## BASELINE REPORT

---

**\*\*Report delivered December 2019. Some contents may not be current.\*\***

This page intentionally left blank.

## TABLE OF CONTENTS

---

1. INTRODUCTION.....	1
2. DEMOGRAPHIC OVERVIEW.....	1
3. CURRENT AND PROJECTED WASTE GENERATION.....	1
4. ESTIMATED MATERIAL COMPOSITION.....	3
5. SUMMARY OF EXISTING CONTRACTUAL AGREEMENTS.....	8
6. DISPOSAL AND PROCESSING INFRASTRUCTURE.....	9

# TABLE OF CONTENTS

---

## List of Figures

Figure 4-1 Recoverability of Refuse.....	5
Figure 4-2 Estimated C&D Waste Composition by Class.....	8
Figure 5-1 Contract Expirations and Optional Extensions.....	9

## List of Tables

Table 2-1 Current and Projected Demographics .....	1
Table 3-1 Historic and Projected Waste Generation (Tons).....	2
Table 3-2 Estimated MSW Generation Tons by Generator Sector and Material Stream (2018) .....	2
Table 3-3 Estimated Residential MSW Generation by Lbs per Household (2018).....	3
Table 4-1 Estimated Boston Mountain/Benton County Refuse Waste Composition (2018) .....	4
Table 4-2 Estimated Boston Mountain/Benton County C&D Waste Composition (2018).....	7
Table 6-1 Landfills within 100 Miles of Fayetteville.....	10
Table 6-2 Transfer Stations within 30 Miles of Fayetteville.....	10
Table 6-3 Recycling Facilities within 30 Miles of Fayetteville.....	11
Table 6-4 Citizen Convenience Centers in the Districts.....	12
Table 6-5 Organics Processing Facilities.....	12

# BOSTON MOUNTAIN SOLID WASTE DISTRICT BASELINE SYSTEM REPORT

---

## 1. INTRODUCTION

Boston Mountain Solid Waste District (BMSWD) has experienced significant growth since 1990 and expects to finish the current decade at over 31 percent growth for this decade. With population and economic growth come greater waste materials to manage. As the district strives to provide leadership and planning for environmentally sound and economically feasible integrated solid waste management for the region, focus is given to waste reduction, reuse, recycling, composting, disposal, and education.

The purpose of this report is to establish the baseline of current material generation and existing infrastructure to manage these materials in the region and provide projections for future planning based on the region’s growth rate.

## 2. DEMOGRAPHIC OVERVIEW

A breakdown of population by the Boston Mountain and Benton County Solid Waste District regions is provided in Table 2-1 below. As shown, 28 to 30 percent growth is expected over the next decade for the two Districts.

**Table 2-1 Current and Projected Demographics**

District	Parameter	2010	2018	2020	2025	2030
Benton	Population	221,339	273,588	288,768	327,217	369,305
	Single-family Households	65,024	80,373	84,833	97,094	111,128
	Multi-family Households	15,711	19,419	20,497	23,459	26,850
Boston Mountain	Population	218,782	255,863	270,809	310,100	353,425
	Single-family Households	57,502	67,024	71,075	82,347	95,464
	Multi-family Households	23,087	27,206	28,947	33,800	39,467
<b>Combined</b>	<b>Total Population</b>	<b>440,121</b>	<b>529,451</b>	<b>559,577</b>	<b>637,317</b>	<b>722,731</b>
	<b>Total Single-family Households</b>	<b>122,526</b>	<b>147,397</b>	<b>155,908</b>	<b>179,441</b>	<b>206,592</b>
	<b>Total Multi-family Households</b>	<b>38,797</b>	<b>46,626</b>	<b>49,443</b>	<b>57,259</b>	<b>66,317</b>

Arkansas Economic Development Institute. *Time Series Extrapolations, 2014-2065 – Vintage 2010 (based on Census 2010)*.

Benton County Solid Waste District. *Regional Needs Assessment 2018*.

Boston Mountain Regional Solid Waste Management District. *2018 Regional Needs Assessment*.

U.S. Census Bureau. *2017 American Community Survey 1-Year Estimates*.

U.S. Census Bureau, Population Division. *Annual Estimates of the Resident Population: April 1, 2010 to July 1, 2018*.

## 3. CURRENT AND PROJECTED WASTE GENERATION

Tonnages collected from residents was available from six cities in the region. Based on the average generation per household from this data, historic and projected material generation was calculated in conjunction with the population growth over this period. Table 3-1 below displays these results by District. The high growth rate of the region carries through to materials needing managed.

# BASELINE SYSTEM REPORT

**Table 3-1 Historic and Projected Waste Generation (Tons)**

District	Waste Type	2010	2018	2020	2025	2030
Benton	MSW	161,036	199,050	210,095	238,068	268,690
	C&D	40,259	49,763	52,524	59,517	67,172
	<i>Subtotal</i>	<i>201,295</i>	<i>248,813</i>	<i>262,618</i>	<i>297,585</i>	<i>335,862</i>
Boston Mountain	MSW	154,682	181,125	191,776	219,800	250,727
	C&D	38,670	45,281	47,944	54,950	62,682
	<i>Subtotal</i>	<i>193,352</i>	<i>226,407</i>	<i>239,720</i>	<i>274,750</i>	<i>313,408</i>
<b>Combined</b>	<b>MSW</b>	<b>315,718</b>	<b>380,176</b>	<b>401,870</b>	<b>457,868</b>	<b>519,416</b>
	<b>C&amp;D</b>	<b>78,930</b>	<b>95,044</b>	<b>100,468</b>	<b>114,467</b>	<b>129,854</b>
<b>Total</b>		<b>394,648</b>	<b>475,219</b>	<b>502,338</b>	<b>572,335</b>	<b>649,271</b>

Construction & Demolition (C&D) waste assumed to be 20% of total generation, based on findings of recent Midwestern waste characterization studies and the growth rate of the NW Arkansas region.

Table 3-2 further defines the breakdown of MSW materials into refuse, recycling and yard waste for 2018 based on the type of account generating the waste - single-family residential, multi-family residential and commercial.

**Table 3-2 Estimated MSW Generation Tons by Generator Sector and Material Stream (2018)**

District	Generator Sector	Households	Refuse	Recycling	Yard Waste	Total
Benton	Single-family	80,373	65,903	9,113	5,234	80,250
	Multi-family	19,419	13,900	1,409	202	15,512
	Commercial	N/A	86,454	11,399	5,436	103,289
	<i>Subtotal</i>	<i>99,792</i>	<i>166,257</i>	<i>21,921</i>	<i>10,872</i>	<i>199,050</i>
Boston Mountain	Single-family	67,024	54,957	7,599	4,364	66,921
	Multi-family	27,206	19,474	1,974	283	21,732
	Commercial	N/A	77,840	9,985	4,648	92,472
	<i>Subtotal</i>	<i>94,230</i>	<i>152,271</i>	<i>19,558</i>	<i>9,296</i>	<i>181,125</i>
<b>Combined</b>	<b>Single-family</b>	<b>147,397</b>	<b>120,861</b>	<b>16,712</b>	<b>9,598</b>	<b>147,171</b>
	<b>Multi-family</b>	<b>46,626</b>	<b>33,374</b>	<b>3,383</b>	<b>486</b>	<b>37,243</b>
	<b>Commercial</b>	<b>0</b>	<b>164,293</b>	<b>21,384</b>	<b>10,084</b>	<b>195,761</b>
	<b>Total MSW</b>	<b>194,023</b>	<b>318,528</b>	<b>41,479</b>	<b>20,168</b>	<b>380,176</b>

Commercial: Residential generation of Refuse and Recycling is estimated to be 52%:48% for Benton and Washington Counties, 35%:65% for Madison County. Commercial Yard Waste is assumed to be equal to the amount of Yard Waste resulting from the residential sector.

Focusing particularly on residential generation of materials, Table 3-3 provides the typical breakdown per account into refuse, recycling and yard waste. As shown, generation by a single-family household is approximately 37 pounds per week, as opposed to multi-family generation of 30 pounds per week.

**Table 3-3 Estimated Residential MSW Generation by Lbs per Household (2018)**

Generator		Lbs/HH/Wk	Lbs/HH/Yr
Single-family	Refuse	31.5	1,639.9
	Recycling	4.4	226.8
	Yard Waste	2.5	130.2
	<b>Single-family Total</b>	<b>38.4</b>	<b>1,996.9</b>
Multi-family	Refuse	27.5	1,431.6
	Recycling	2.8	145.1
	Yard Waste	0.4	20.8
	<b>Multi-family Total</b>	<b>30.7</b>	<b>1,597.5</b>

#### **4. ESTIMATED MATERIAL COMPOSITION**

To consider what materials actually make up the material stream for use in material management, diversion targets, and planning processing and disposal infrastructure, the results of recent waste characterizations completed in Fayetteville, Lexington (KY) and demographically comparable areas of the Missouri statewide study were averaged and applied to the tonnages by District. Table 4-1 provides a breakdown of materials based on 2018 tonnage.



# BASELINE SYSTEM REPORT

Table 4-1 Estimated Boston Mountain/Benton County Refuse Waste Composition (2018)

Material Category	Composition Estimate	Benton Tons	Boston Mountain Tons	Combined Tons
<b>Paper</b>	<b>25.8%</b>	<b>42,822</b>	<b>39,220</b>	<b>82,042</b>
Newspaper	1.6%	2,702	2,475	5,177
Corrugated Containers	8.5%	14,052	12,870	26,922
Office Paper	1.8%	2,910	2,665	5,576
Other Recyclable Paper	5.2%	8,648	7,920	16,568
Low Grade Paper	8.7%	14,510	13,289	27,799
<b>Plastics</b>	<b>14.8%</b>	<b>24,529</b>	<b>22,466</b>	<b>46,995</b>
PET Containers	1.4%	2,328	2,132	4,461
HDPE Containers	0.9%	1,455	1,333	2,788
Other Non-Bottle Plastics #1 and #2	0.5%	831	762	1,593
Other Plastic Containers (#3-#7)	1.3%	2,120	1,942	4,062
Bulky Rigid Plastics	1.3%	2,203	2,018	4,222
Expanded Polystyrene #6	0.8%	1,289	1,180	2,469
Retail Bags	0.6%	998	914	1,912
Non-Rigid Plastic Film	6.2%	10,352	9,481	19,833
All Other Plastics	1.8%	2,952	2,703	5,655
<b>C&amp;D</b>	<b>14.4%</b>	<b>23,989</b>	<b>21,971</b>	<b>45,959</b>
C&D Debris	6.4%	10,602	9,710	20,311
Clean Wood Waste	4.4%	7,317	6,702	14,019
Treated Wood Waste	3.7%	6,070	5,559	11,629
<b>Glass</b>	<b>3.2%</b>	<b>5,322</b>	<b>4,874</b>	<b>10,195</b>
Glass Containers	2.8%	4,615	4,227	8,841
Other Glass	0.4%	707	647	1,354
<b>Organics</b>	<b>18.3%</b>	<b>30,433</b>	<b>27,873</b>	<b>58,305</b>
Food Waste	15.5%	25,818	23,646	49,464
Yard Waste	2.8%	4,615	4,227	8,841
<b>Metals</b>	<b>3.7%</b>	<b>6,070</b>	<b>5,559</b>	<b>11,629</b>
Tin/Steel Cans	1.1%	1,829	1,675	3,505
Aluminum Cans	0.7%	1,164	1,066	2,230
Other Ferrous	1.2%	1,954	1,790	3,744
Other Non-Ferrous	0.7%	1,123	1,028	2,151
<b>Other</b>	<b>19.9%</b>	<b>33,093</b>	<b>30,310</b>	<b>63,403</b>
Electronics	1.2%	2,037	1,866	3,903
Textiles	4.0%	6,569	6,016	12,585
Tires and Rubber	1.1%	1,829	1,675	3,505
Household Hazardous Waste	0.5%	873	800	1,673
Liquids	0.4%	624	571	1,195
Grit	1.9%	3,201	2,932	6,133
All Other Garbage	10.8%	17,960	16,449	34,410
<b>Total</b>	<b>100.0%</b>	<b>166,257</b>	<b>152,271</b>	<b>318,528</b>

To further utilize the material characterization, the materials were all assigned a status. Figure 4-1 presents the composition of generated materials in terms of the potential for diverting and recovering materials from disposal. This figure was developed by assigning a “Diversion Strategy” to each individual material category. Specifically, each material was defined as one of the four categories listed below.

- ◆ **Curbside Fiber:** Includes recyclable fiber (e.g., newspaper, corrugated containers, office paper and other recyclable paper),
- ◆ **Curbside Containers:** Includes recyclable containers (e.g., #1 and #2 plastic bottles, metal cans, and glass jars and bottles).
- ◆ **Compostables:** Includes compostable organics other than yard waste (e.g., food waste, clean wood wastes).
- ◆ **Yard Waste:** Includes yard wastes. Yard Waste is banned from landfills in Arkansas.
- ◆ **Recyclable through Third Party:** Includes recyclables other than curbside recyclables that can typically be accepted at third party recyclers, reuse/donation centers, or retailers, (e.g., Other Ferrous, Other Non-Ferrous, Textiles, Tires and Rubber).
- ◆ **Household Hazardous Waste:** Includes materials processed at specialized facilities, and/or through special collection programs/events.
- ◆ **E-waste:** Includes electronics as collected at special facilities, and/or through special collection programs/events.
- ◆ **Non-Recoverable:** Includes all other materials that are not currently recyclable (or are recycled only minimally) in the Boston Mountain and Benton County Solid Waste District areas (e.g., low grade paper, various plastics, non-container glass, C&D Debris, wood). There may be some recovery of certain of these materials, but it is not believed recycling of these materials is widespread.

As shown, 24.8 percent (Yard Waste and Compostables) could be composted if separated from the other materials, and approximately 26.2 percent is recyclable through curbside (and drop-off) programs.

**Figure 4-1 Recoverability of Refuse**

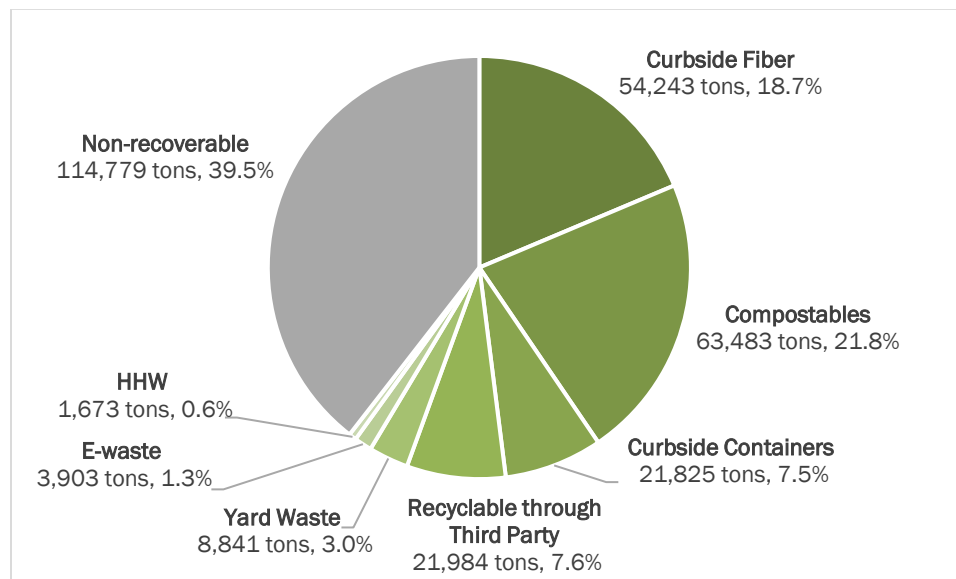

When considering C&D waste specifically, Table 4-2 provides the estimated volumes of materials commonly occurring in construction and demolition type loads. This composition was also based on actual findings of waste characterization studies previously completed in the Midwest. Figure 4-2 provides

## **BASELINE SYSTEM REPORT**

---

a breakdown by material class. As shown, materials commonly recovered by C&D recyclers (concrete, rock/gravel, clean wood, roofing materials, and metals) make up over 40 percent of the material stream.

# BASELINE SYSTEM REPORT

**Table 4-2 Estimated Boston Mountain/Benton County C&D Waste Composition (2018)**

Material Category	Composition Estimate	Benton Tons	Boston Mountain Tons	Combined Tons
<b>MSW/Other Waste</b>	<b>7.3%</b>	<b>3,633</b>	<b>3,306</b>	<b>6,939</b>
Flattened OCC	1.2%	603	548	1,151
Unflattened OCC	0.2%	122	111	234
R/C and Other Paper	0.3%	148	135	283
All Glass	0.4%	201	182	383
Electronics	0.7%	339	309	648
Items with CRTs	0.2%	113	103	216
Tree Trunks	0.0%	0	0	0
Fines/Mixed Residue	1.8%	904	823	1,727
Mixed MSW	1.9%	961	874	1,835
Agricultural Waste	0.5%	242	220	462
<b>Plastics</b>	<b>4.7%</b>	<b>2,328</b>	<b>2,118</b>	<b>4,447</b>
Plastic Bottles (Recyclable)	0.0%	0	0	0
HDPE Buckets (stacked)	0.0%	0	0	0
HDPE Buckets (unstacked)	0.0%	12	11	23
Clean Recoverable Film	0.0%	24	22	46
R/C and Other Plastic	4.6%	2,292	2,085	4,377
<b>Metals</b>	<b>3.9%</b>	<b>1,963</b>	<b>1,786</b>	<b>3,749</b>
Appliances	0.1%	50	45	95
Other Ferrous Metals	3.0%	1,495	1,360	2,855
Other Non-ferrous Metals	0.7%	343	312	655
HVAC Ducting	0.2%	75	69	144
<b>Wood</b>	<b>2.5%</b>	<b>1,220</b>	<b>1,111</b>	<b>2,331</b>
Leaves/Grass/Mixed Yard Waste	0.3%	174	158	332
Branches/Limbs	0.1%	38	34	72
R/C and Other Organics	2.0%	1,009	918	1,928
<b>Gypsum Board</b>	<b>14.7%</b>	<b>7,320</b>	<b>6,661</b>	<b>13,981</b>
Clean Gypsum Board	4.1%	2,022	1,840	3,861
Painted Gypsum Board	10.6%	5,299	4,821	10,120
<b>Roofing Materials</b>	<b>7.8%</b>	<b>3,874</b>	<b>3,525</b>	<b>7,399</b>
Roofing Materials	7.8%	3,874	3,525	7,399
<b>Dirt/Sand/Gravel</b>	<b>5.7%</b>	<b>2,836</b>	<b>2,581</b>	<b>5,417</b>
Dirt/Sand/Gravel	5.7%	2,836	2,581	5,417
<b>Other C&amp;D</b>	<b>5.7%</b>	<b>2,844</b>	<b>2,588</b>	<b>5,433</b>
Carpet	2.5%	1,245	1,133	2,377
Carpet Padding	0.3%	125	114	239
Asphalt Paving	0.5%	226	206	432
Ceiling Tiles	0.3%	125	114	239
Insulation	0.9%	459	417	876
R/C and Other C&D	1.3%	665	605	1,269
<b>Special Wastes</b>	<b>11.2%</b>	<b>5,558</b>	<b>5,058</b>	<b>10,616</b>
Bulky Wastes/Furniture	11.1%	5,546	5,047	10,593
Tires - Cut	0.0%	12	11	23
Tires - Whole	0.0%	0	0	0
All HHW	0.0%	0	0	0
Contaminated Soil	0.0%	0	0	0
<b>Wood</b>	<b>20.9%</b>	<b>10,389</b>	<b>9,453</b>	<b>19,842</b>
Pallets - Standard	1.3%	655	596	1,251
Pallets/Crates/Heavy	0.3%	157	143	301
Untreated/Unpainted Lumber	5.5%	2,734	2,487	5,221
Treated/Painted/Processed Wood	5.5%	2,744	2,497	5,241
Engineered Wood	4.0%	1,990	1,811	3,800
Wood Furniture	2.5%	1,230	1,119	2,349
Other Wood	1.8%	879	800	1,679
<b>Concrete/Block/Brick/Stone/Tile</b>	<b>15.7%</b>	<b>7,796</b>	<b>7,094</b>	<b>14,889</b>
Concrete/Block/Brick/Stone/Tile	15.7%	7,796	7,094	14,889
<b>Total</b>	<b>100.0%</b>	<b>49,763</b>	<b>45,281</b>	<b>95,044</b>

**Figure 4-2 Estimated C&D Waste Composition by Class**

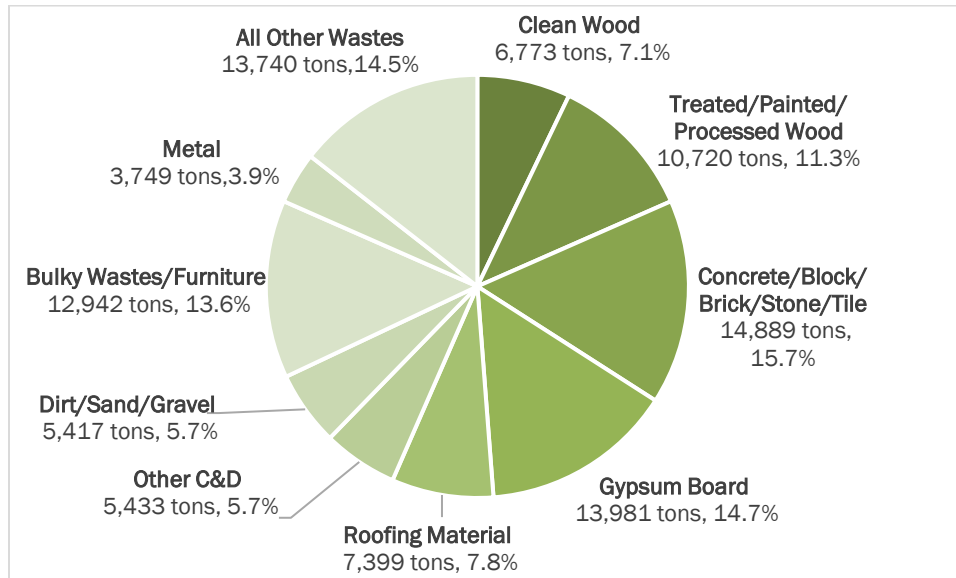

## **5. SUMMARY OF EXISTING CONTRACTUAL AGREEMENTS**

Fifteen of the 37 municipalities in the Boston Mountain and Benton County Solid Waste Districts contract out residential collection, and in many cases recyclables processing and refuse disposal. Figure 5-1 provides a chart of expiration years as well as indicating if there are optional extensions. In planning any regional standardization of curbside recycling, it will be important to keep contract requirements and expirations in mind when establishing any timelines for implementing standardization.

Figure 5-1 Contract Expirations and Optional Extensions

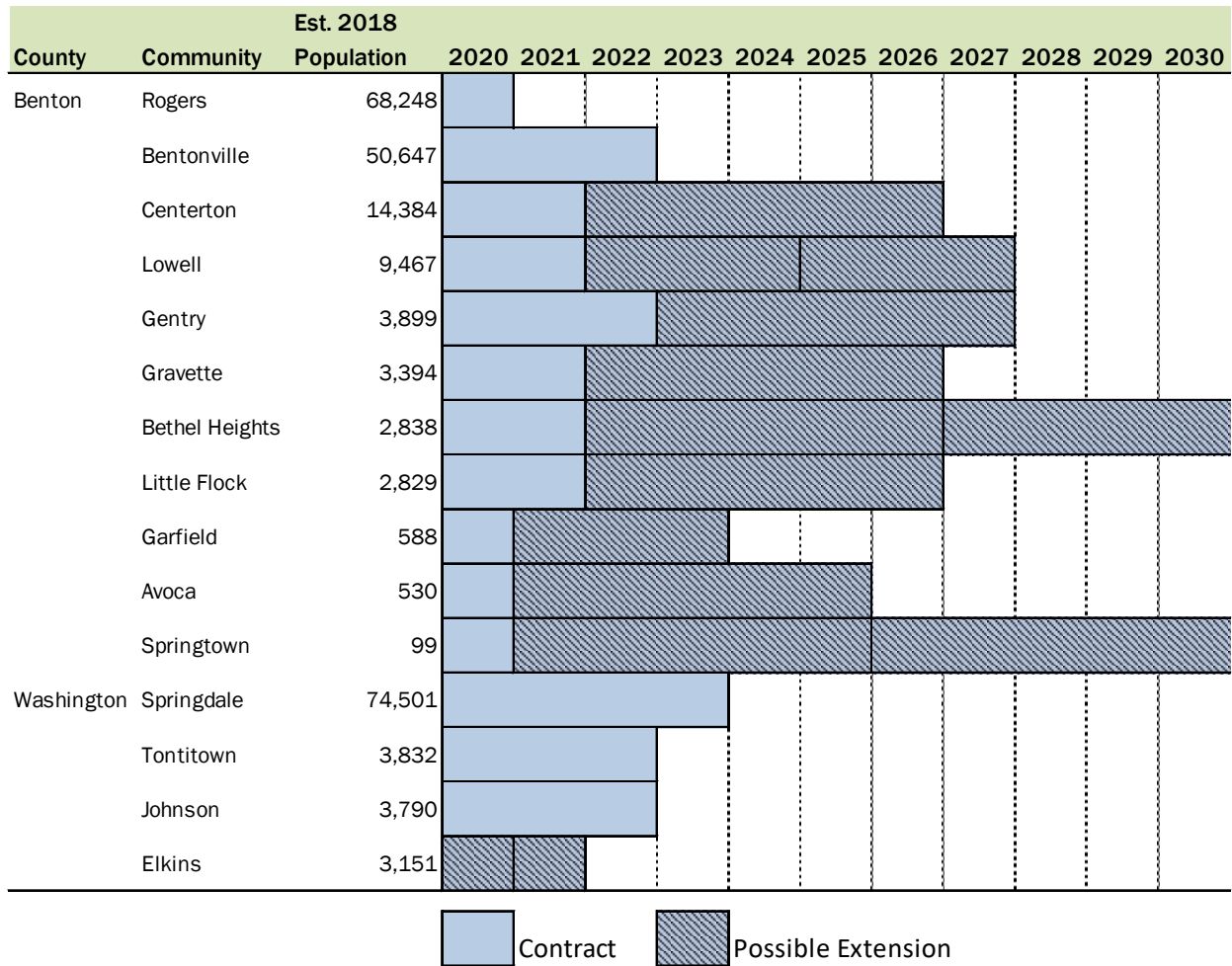

## 6. DISPOSAL AND PROCESSING INFRASTRUCTURE

Being located in the northwest corner of Arkansas, much of the Benton County and Boston Mountain Solid Waste Management Districts are within feasible transfer distance to processing and disposal facilities in Kansas, Missouri and Oklahoma. Using the City of Fayetteville as a central point in the region, Table 6-1 identifies MSW landfills within a 100-mile radius.

# BASELINE SYSTEM REPORT

Table 6-1 Landfills within 100 Miles of Fayetteville

Landfill	Miles from Fayetteville	State	County	Owner
<b>MSW Landfills</b>				
Eco-Vista, LLC	19	AR	Washington	Waste Management of AR, Inc.
City of Fort Smith Sanitary Landfill	49	AR	Sebastian	City of Ft. Smith
Sallisaw Solid Waste Disposal Facility	63	OK	Sallisaw	City of Sallisaw
Ozark Waste Management of AR, Inc.	73	AR	Yell	Ozark Ridge Landfill, Inc.
North Central ARK LF Authority	83	AR	Van Buren	North Central ARK LF Authority
City of Morrilton	90	AR	Conway	City of Morrilton
Northwest AR RSWMD	98	AR	Baxter	NABORS Landfill
<b>C&amp;D Landfills</b>				
Eco-Vista, LLC	19	AR	Washington	Waste Management of AR, Inc.
Muskogee Comm. Landfill & Rec. Ctr.	77	OK	Muskogee	Waste Management
RES C&D Landfill	86	KS	Baxter Springs	RES C&D Landfill
City of Galena	88	KS	Galena	City of Galena
B-3 Construction, Inc.	94	KS	Columbus	B-3 Construction, Inc.
Elliott Construction Co. Landfill	98	OK	Morris	Elliott Construction Co.

Similarly, transfer stations within the region were identified within a 30-mile radius of Fayetteville. Table 6-2 provides a list of seven identified.

Table 6-2 Transfer Stations within 30 Miles of Fayetteville

Transfer Station	Miles from Fayetteville	State	Municipality	Owner
City of Fayetteville TS	0	AR	Fayetteville	City of Fayetteville
American Ideal Trash Services	0	AR	Fayetteville	American Trash Service
Boston Mountain SWD Transfer Station	12	AR	Prairie Grove	Boston Mountain SWD
Bethel Heights TS - WMA	17	AR	Bethel Heights	Waste Management of AR, Inc.
Madison County TS	24	AR	Huntsville	Madison County
City of Siloam Springs TS	25	AR	Siloam Springs	City of Siloam Springs
City of Ozark TS	30	AR	Ozark	City of Ozark

With respect to recycling of various materials, Table 6-3 lists recycling facilities within a 30-mile radius of Fayetteville.



**Table 6-3 Recycling Facilities within 30 Miles of Fayetteville**

Facility	Miles from Fayetteville	State	Municipality
<b>Material Recovery Facility/Recycling Center</b>			
Benton County SWMD	25	AR	Bentonville
Boston Mountain SWMD	14	AR	Prairie Grove
City of Bella Vista Recycling	30	AR	Bella Vista
City of Fayetteville	0	AR	Fayetteville
City of Rogers	26	AR	Rogers
City of Siloam Springs	27	AR	Siloam Springs
Marck Industries, Inc.	26	AR	Rogers
<b>Scrap Metal Recovery</b>			
Roll Off Services, Inc.	12	AR	Fayetteville
Rogers Iron and Metal	17	AR	Rogers
4 D Disposal	24	AR	Huntsville
Siloam Springs Metal Recycling Corp	27	AR	Siloam Springs
<b>C&amp;D Recovery</b>			
Northwest AR Recovery, Inc.	0	AR	Springdale
Eco-Vista, LLC	17	AR	Tontitown
Energy Source, LLC	30	AR	Gentry
USA Metal Recycling	21	AR	Lowell

Whereas all communities do not have curbside recyclable collection available, the region has several citizen convenience drop-off centers that provide the opportunity to recycle. In some cases, such as the City of Fayetteville, multiple sites are provided. These facilities are listed in Table 6-4 below.

# BASELINE SYSTEM REPORT

**Table 6-4 Citizen Convenience Centers in the Districts**

County	Facility	Municipality	
Benton	Bella Vista Recycling Center	Bella Vista	
	Benton County SWMD	Bentonville	
	Boston Mountain SWMD	Prairie Grove	
	City of Bethel Heights	Bethel Heights	
	City of Cave Springs	Cave Springs	
	City of Gentry	Gentry	
	City of Siloam Springs	Siloam Springs	
	eSCO Processing & Recycling, LLC	Rogers	
	Gravette Drop-Off	Gravette	
	Marck Industries of N.W. Ar	Rogers	
	Pea Ridge Drop-Off	Pea Ridge	
	Rogers Community Recycling	Rogers	
	Springdale Recycling Yard, Hutchens Cons.	Springdale	
	Used Oil Service Co. Inc.	Springdale	
	Madison	Madison County Solid Waste/Rec	Huntsville
	Washington	City of Farmington	Farmington
		City of Fayetteville	Fayetteville
City of Prairie Grove		Prairie Grove	
City of West Fork		West Fork	
Smurfit Kappa - Johnson, AR Rec Plant		Johnson	
Springdale Recycling Center		Springdale	
Univ of AR Razorback Recycling		Fayetteville	
Vaughn Recycling		Fayetteville	
	Washington County Env.Affairs	Fayetteville	

Organics processing is a component of integrated solid waste management that has begun to pick up across the country. Current processors of organics in the Boston Mountain and Benton County Solid Waste Districts region are listed in Table 6-5 below.

**Table 6-5 Organics Processing Facilities**

Facility	Miles from Fayetteville	State	Municipality
Benton County SWMD	26	AR	Rogers
City of Fayetteville	0	AR	Fayetteville
City of Bentonville	29	AR	Bentonville
Eco-Vista, LLC	19	AR	Tontitown

---

# APPENDIX B

## PROJECT INFORMATIONAL FLIER

---

This page intentionally left blank.

# Invitation to Participate



The Boston Mountain Solid Waste Management District (Washington & Madison counties) has hired a team to complete a 10 Year Regional Recycling and Solid Waste Management Plan to guide the future of our regional solid waste management.

MSW Consultants has teamed with Kessler Consulting to provide these services. The initial phase will consist of inventorying the existing system, infrastructure and market dynamics in the region.

Phase II will be an engagement of regional constituents to formulate priorities and future plans for opportunities such as:



Increasing Organics Diversion



Increasing Construction & Demolition Diversion



Standardizing Commodities & Messaging



Long-term Visioning for Recycling

We are asking  
*You to participate*  
in this process by:

- i** Providing and/or clarifying information about your system
- i** Sharing ideas for future direction of regional solid waste management
- i** Exploring ways to increase consistency in a region with many unique recycling programs
- i** Helping build consensus



For more information contact

**Robyn Reed**, Director | [reed@bmswd.com](mailto:reed@bmswd.com) | 479-846-4617

**Lee Chalmers**, Special Projects Coordinator | [chalmers@bmswd.com](mailto:chalmers@bmswd.com) | 479-313-9076

This page intentionally left blank.

---

# APPENDIX C

## INITIAL PRESENTATION TO STAKEHOLDERS

---



This page intentionally left blank.

# Regional Recycling & Organics Standardization

1

PRESENTED TO:

BOSTON MOUNTAIN AND BENTON COUNTY  
SOLID WASTE DISTRICT STAKEHOLDERS

FEBRUARY 2020



1

## About the Team

2

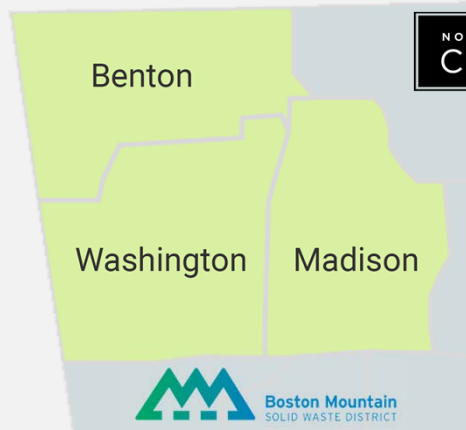

2

## Project Overview

3

- **Boston Mountain/Benton County Regional Plan to:**
  - Explore Standardizing Residential Recycling Programs
    - ✦ Develop alternative scenarios for collection and processing
    - ✦ Standardized messaging/education
- **Boston Mountain SWD Plan also addressing:**
  - Explore Possible Reductions to MSW-associated costs by
    - ✦ Increasing Organics Diversion
    - ✦ Increasing C&D Diversion

3

## Regional Recycling Solutions

4

### EXAMPLES

4

## City of Milwaukee / Waukesha County MRF

5

- **Issues that brought about the agreement:**

- City was maintaining a dated MRF as TS and shipping materials to Germantown (30+min) for processing.
- County was seeking to go to single stream from dual stream.
  - (576 sq miles / 37 municipalities / combined population of over 389,000)
- Only MRF was privately owned dual stream – no space for single-stream equipment.
- City and County agreed to seek options if combined tonnage made economic sense.

- **Results:**

- Partnership RFP process reduced MRF capital expenses and operating costs per ton.
- City and County Retrofitted dated MRF in Menomonee
- Began operations in 2015
- Serves over 20 communities in Waukesha County
- State of art equipment (processes 35 tons/hr.)
- Single sort facility



5



## Southeast Iowa (Quad City Area)

6

- **Inter-governmental agency established in 1972, reorganized in 1990**
  - 17 communities (incl. Davenport and Bettendorf, and Scott County – regional population 250,000)
- **Dual-Stream Recycling Center constructed in 1995; Single-Stream renovation in 2016** (partially funded by 0% interest Closed Loop Fund loan)
- **FY2016 DS tonnage = 5,742; FY2019 SS tonnage = >33,000**
- **\$80/ton processing fee; Revenue sharing with communities if revenue/ton is >\$80, not breaking even with current markets**
- **Currently running two 10-hour shifts, 4 days/wk, 11 T/hour**
- **Currently, 36,000 tons coming from as far as 100 miles away**

*“Without a doubt, single-stream. Collection is more efficient and much safer...volume from largest 2 cities increased by 60%.”*

*Kathy Morris, Director*



6

## Existing Conditions

7

- Recycling collection and processing varies across the region
- Regional processing tonnage will soon exceed current processing capacity
- One landfill currently serving the region

7

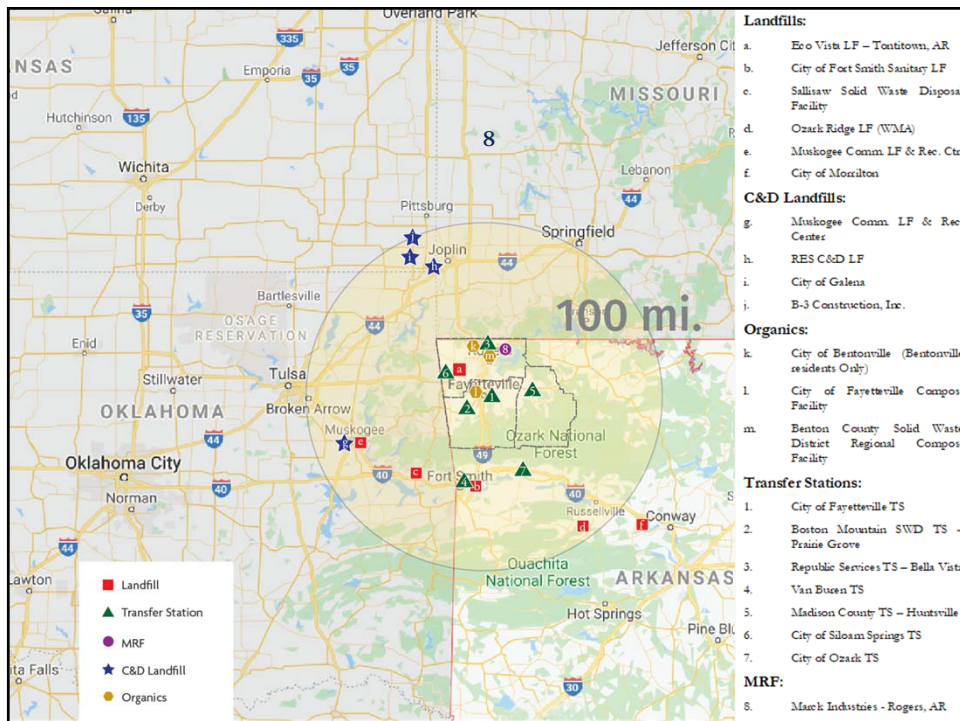

8

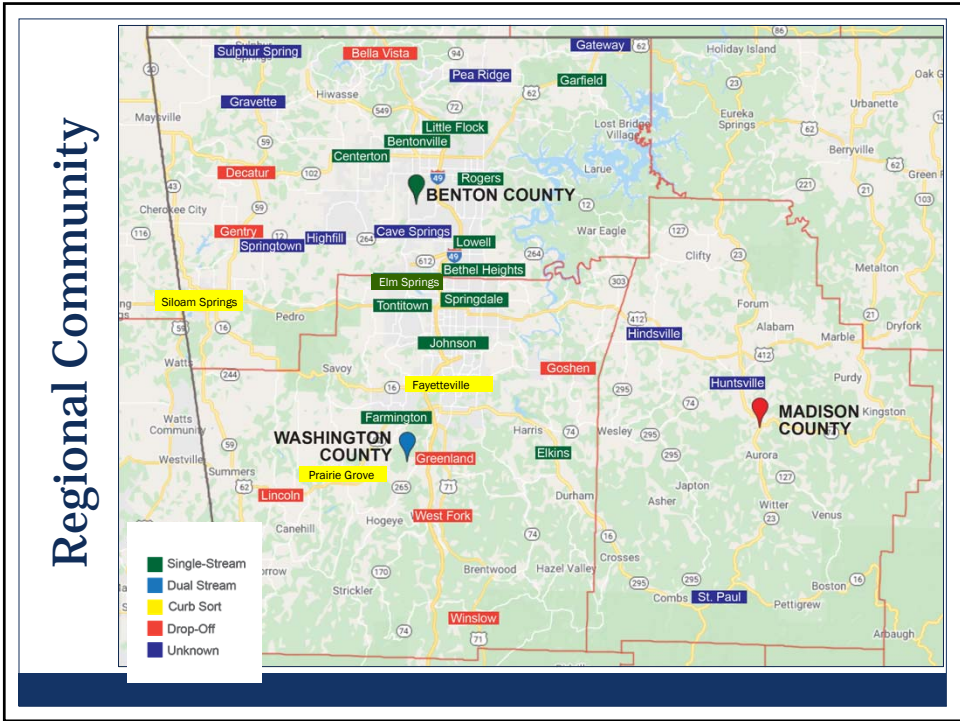

9

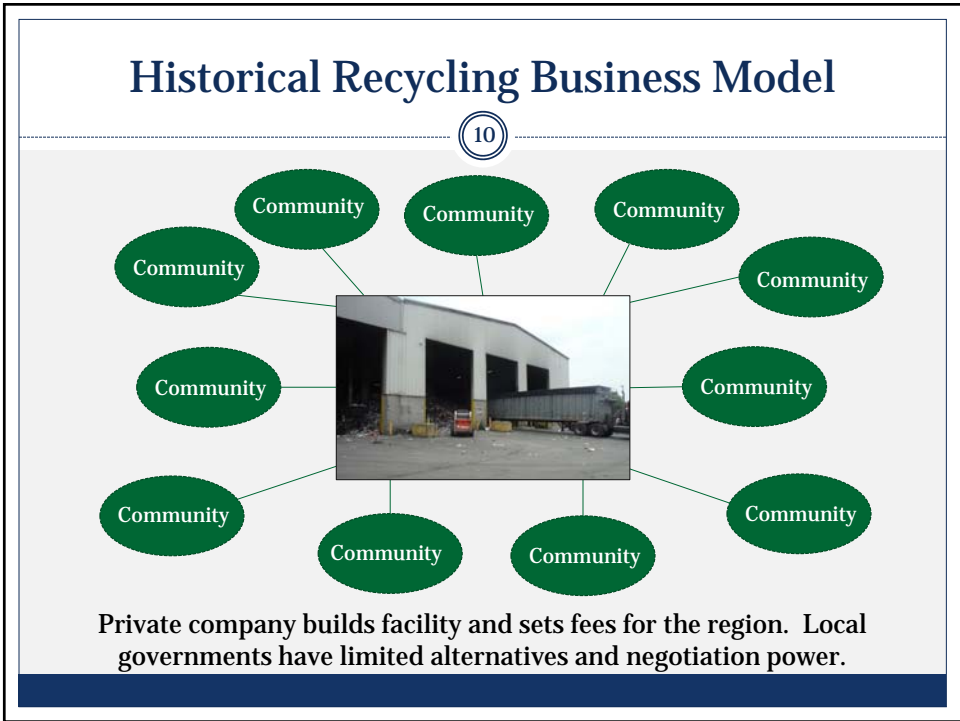

10

## Historical Recycling Economics

11

\$120/ton material value

\$50/ton processing cost

<10% contamination



11

## Current Recycling Economics

12

\$40/ton material value

\$100+/ton processing fee

>20% contamination



12



## Conclusion

13

**“Private industry will not unilaterally develop large-scale recycling processing capacity.”**

13

**What will it take for Northwest Arkansas local governments and solid waste management districts to join together and create a standardized regional recycling solution?**

14

14

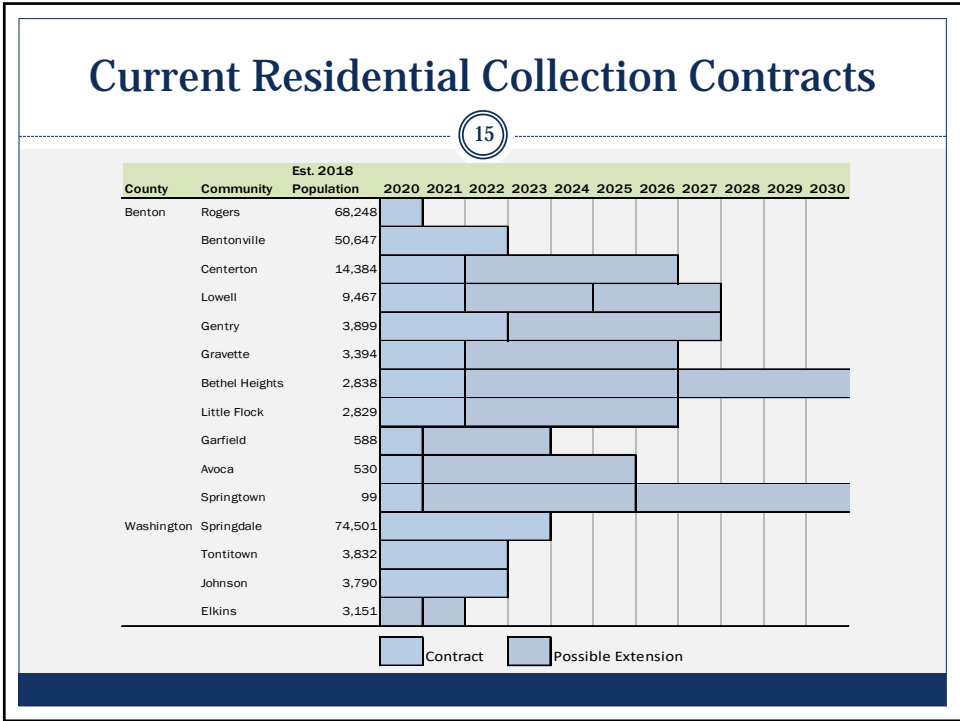

15

## Thank you for your input...

16

- **Challenges of current systems**
- **Concerns about future direction**
- **Vision and priorities**
  - Are you interested in recycling more?
  - How does your community feel about putting recoverable material in the landfill?
  - Does it make sense for the communities to work together?

16

This slide features a dark green header with the title "NW Arkansas Regional Recycling Vision" in white text. Below the header is a white area with a small circular icon containing the number 17. The slide is framed by a dark blue footer bar.

17

This slide features a white header with the title "Regional Recycling Vision" in dark blue text. Below the header is a light gray area with a small circular icon containing the number 18. The slide is framed by a dark blue footer bar.

- Long-term commitments from the districts and local governments
- Affordable to residents and businesses
- Clearly understood transition schedule from current programs to regional standard for those opting in to a standardized regional system
- Uniform public education to convey clear and consistent program details, decrease contamination rates, and increase participation and diversion
- Best-in-class diversion performance to maximize regionally sustainable waste management
- Flexibility to deliver recycling service using preferred strategy

18

## Next Steps

19

- **Consultant Team:** review what we have learned and heard from you
- **Consultant Team and Districts:** formulate conceptual regional infrastructure plan and logical path forward
- **Stakeholders:** Review conceptual plan and identify improvements
- **Consultant Team**
  - Compile recommendations
  - Formulate plan
  - Inform regional stakeholders

19

## Other Initiatives

20

### Organics Processing



### C&D Diversion



20

# Thank you

21

**John Culbertson, Principal**  
407/380-8951  
[jculbertson@mswconsultants.com](mailto:jculbertson@mswconsultants.com)

**Chas Jordan, Sr. Consultant**  
813/971-8333, x29  
[cjordan@kesconsult.com](mailto:cjordan@kesconsult.com)

**Cynthia Mormile, Sr. Project Manager**  
573/818-2281  
[cmormile@mswconsultants.com](mailto:cmormile@mswconsultants.com)

**Bethany Jewell, Consultant**  
813-971-8333, x15  
[bjewell@kesconsult.com](mailto:bjewell@kesconsult.com)

This page intentionally left blank.

---

**APPENDIX D**  
**PRELIMINARY FINDINGS**  
**PRESENTATION TO STAKEHOLDERS**

---

This page intentionally left blank.



# Regional Recycling Standardization Plan - Project Update

1

PRESENTED TO:





BOSTON MOUNTAIN AND BENTON COUNTY  
SOLID WASTE DISTRICT STAKEHOLDERS

NOVEMBER 19, 2020



## Overview

2

- Recycling Standardization & Diversion Potential  
- Organics Diversion Potential 
- C&D Diversion Potential 

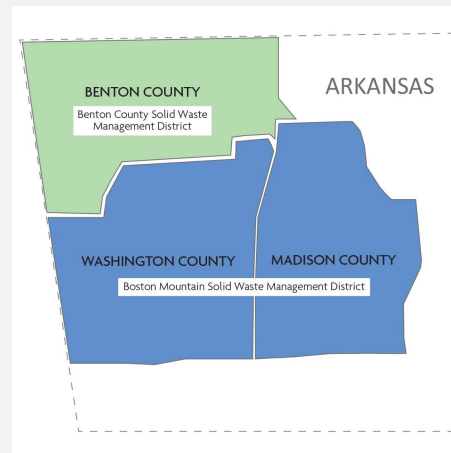

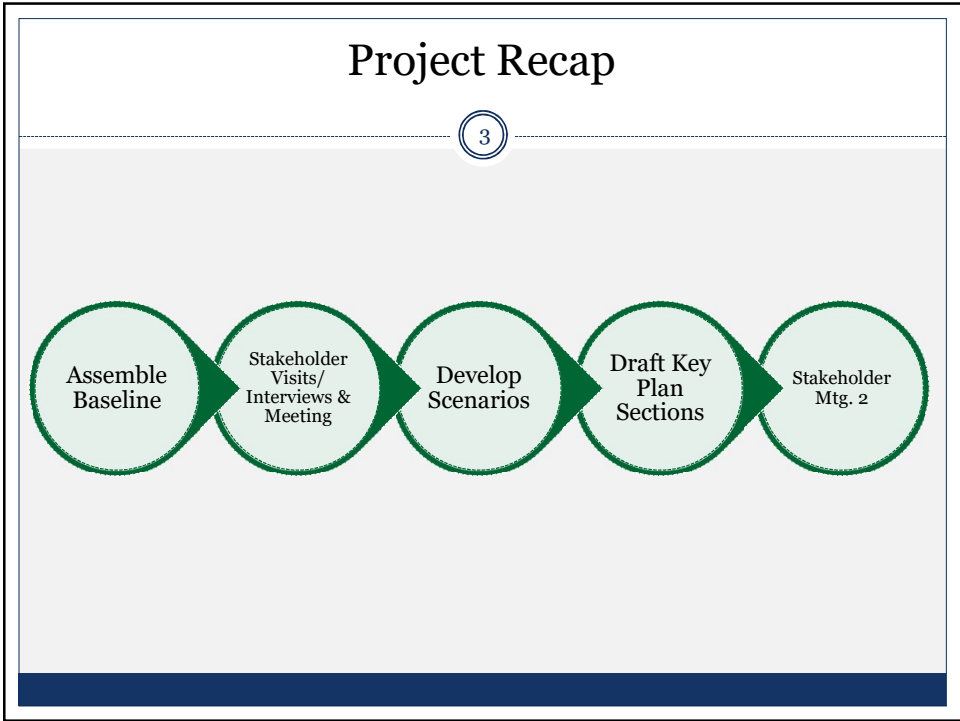

## Recycling Standardization & Diversion

4

The slide features a dark green header with the text 'Recycling Standardization & Diversion' in white. Below the header is a small circle containing the number '4'. The rest of the slide is white, with a dark blue horizontal bar at the bottom.

## Current Recycling Collection Methods

5

Municipal Population Served

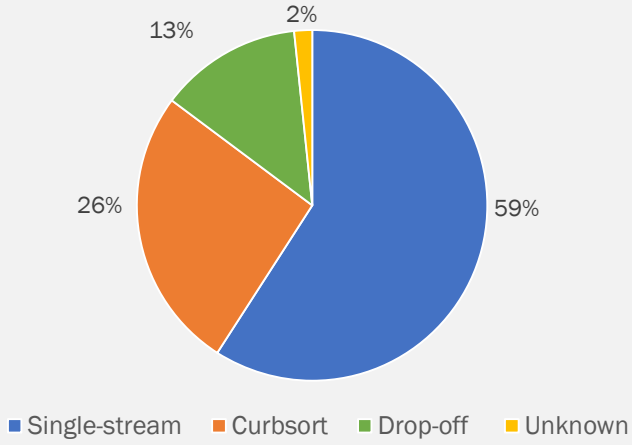

## Collection Methods

6



## Current Curbside System Performance

7

Regional Avg. Lbs. per Household  
Recycled per Year  
(Bentonville, Fayetteville, Johnson, Prairie Grove,  
Siloam Springs)



High Performing System Avg. Lbs.  
per Household Recycled per Year\*



\*Source: The Recycling Partnership: "2020 State of Curbside Recycling" report

## Tons of Recyclables

8

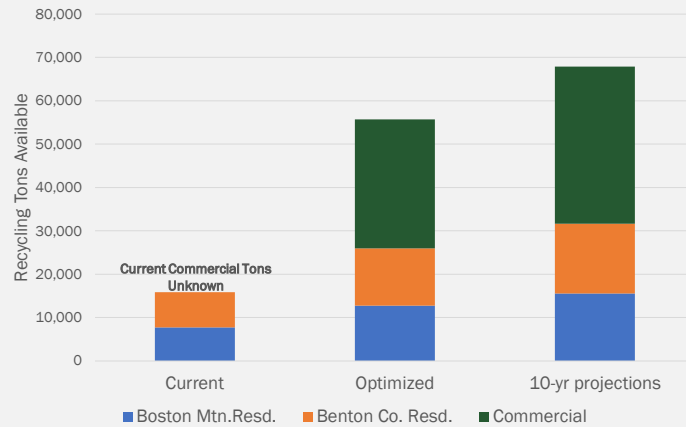

## Current Residential Collection Contracts

9

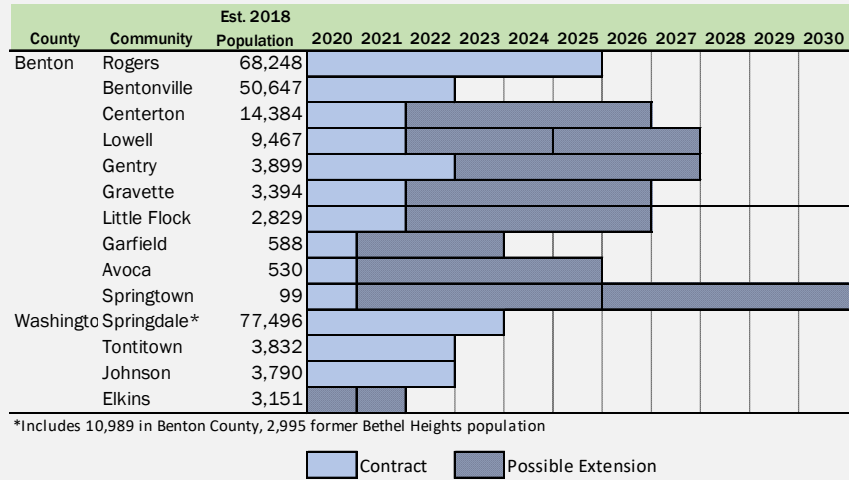

NOTE: Contracts include disposal and processing. Hauler contracts with landfill/MRF.

## Historical Material Pricing

10

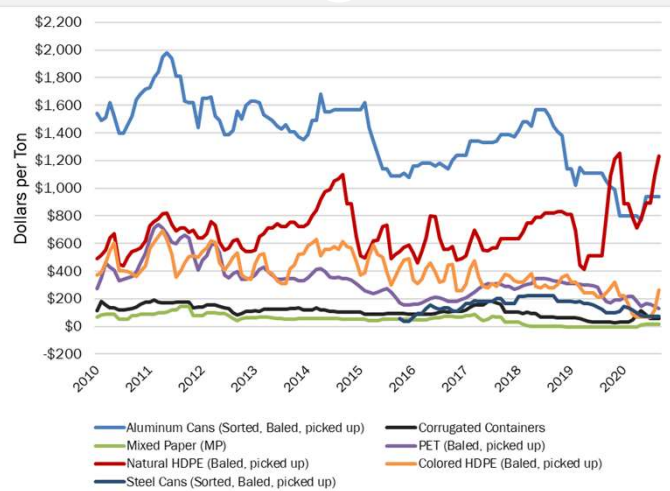

Source: RecyclingMarkets.net Midwest Region

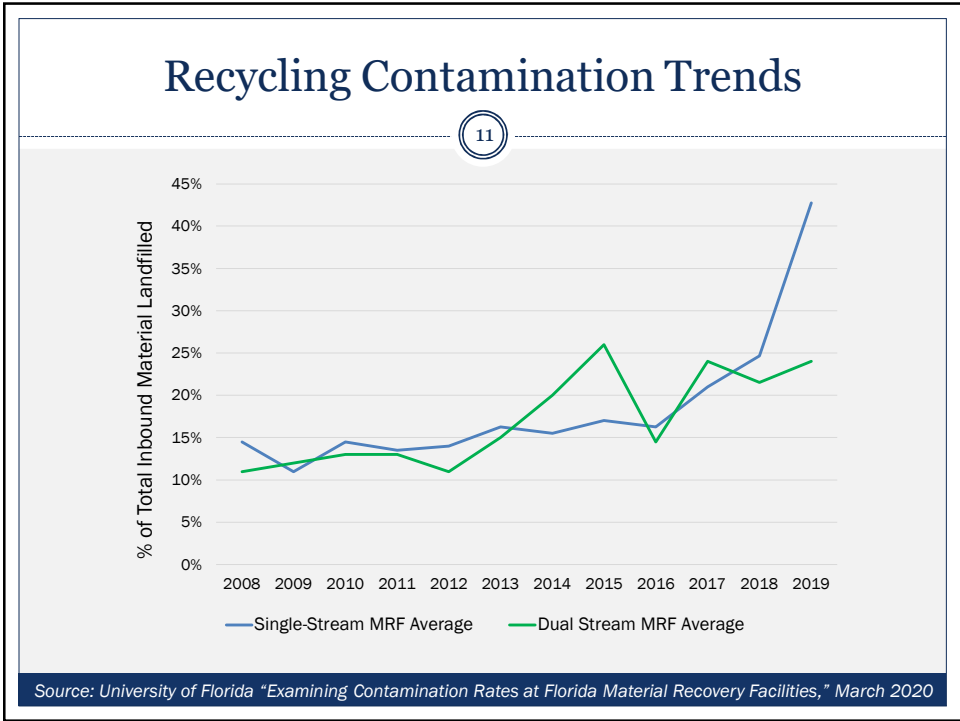

### Market Value Comparison

12

	Curbsort Mix	Single-Stream Mix
Residue as % of Outbound Materials	2.3%	20.0%
Blended Value per Ton	\$56.95	\$38.06

Source: Material % estimated by MSW Consultants; pricing from RecyclingMarkets.net

# Marck Industries

13

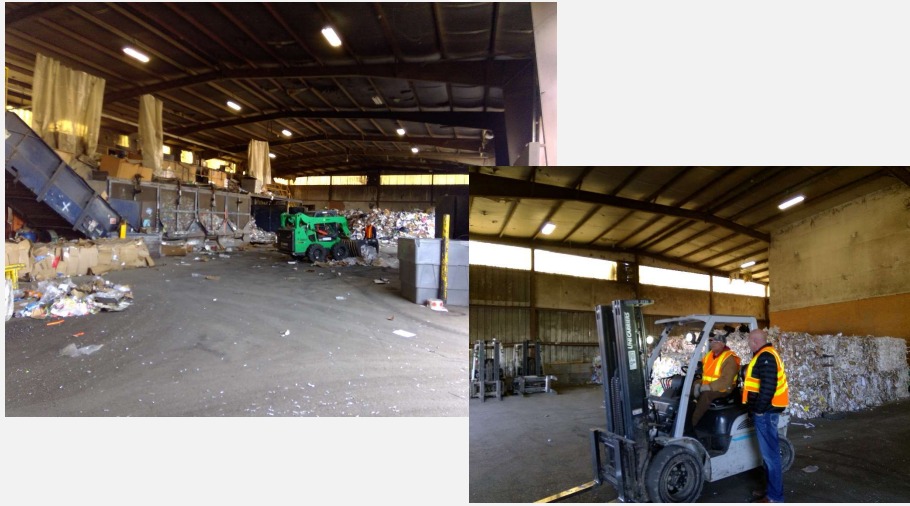

# MRF Processing Fees

14

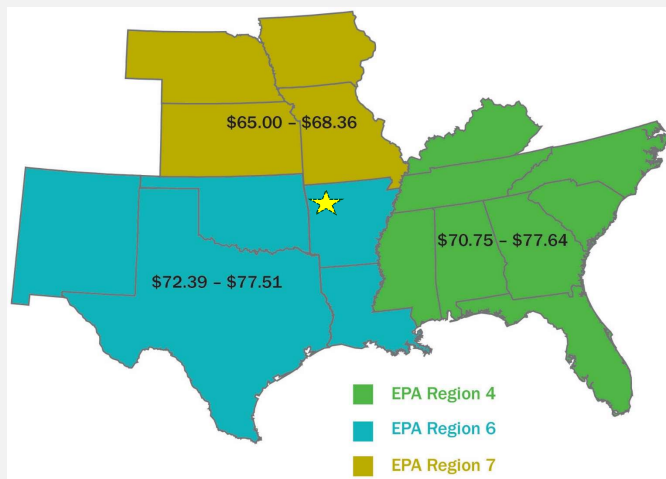

Source: The Recycling Partnership: "2020 State of Curbside Recycling" Report

## Regional Recycling Program Vision

15

- **Standardization of materials**
- **Regional recyclables processing infrastructure**
- **Management** of the regional system

...and a long-term path for migration to a standard curbside collection system

## Standardized Materials

16

- **Universally Targeted**



- **Optional**





## Positive Attributes of Automated or Semi-Automated Cart Collection

17

- Safety
- Collection efficiency
- Protection from precipitation
- Litter prevention
- Uniform neighborhood aesthetics
- Single-stream MRFs have become prevalent nationally for large volume regions



## MRF Options

18

One Regional MRF  
or  
Two (or more)  
MRFs

Residential Only  
or  
Residential &  
Commercial

Single-Stream  
or  
Dual Stream

## Levels of MRF Complexity

19



## MRF Options Evaluated

20

	Two MRFs (One per District) Residential		One Regional MRF Residential		One Regional MRF Resd. & Commercial		
	Option 1	Option 2	Option 3	Option 4	Option 5	Option 6	Option 7
<b>Process Type</b>	Single Stream	Dual Stream	Single Stream	Dual Stream	Single Stream	Dual Stream	Multi-Stream
Design Capacity	17,500	17,500	35,000	35,000	70,000	70,000	70,000
No. of MRFs	2	2	1	1	1	1	1
Acres (per MRF)	3.5	2.5	4.0	3.0	6.0	6.0	6.0
Capital Cost	\$29,950,000	\$17,960,000	\$21,460,000	\$12,950,000	\$27,380,000	\$19,430,000	\$29,050,000
Net Annual Cost	\$3,380,000	\$2,120,000	\$1,890,000	\$900,000	\$2,270,000	\$1,000,000	\$2,380,000
Tons	35,000	35,000	35,000	35,000	70,000	70,500	70,500
Per Ton	\$97	\$61	\$54	\$26	\$32	\$14	\$34

Note: Capital cost does not include land acquisition

## Other Options

21



Multiple Mini MRFs



Transfer to distant MRF

...or Status Quo

## Optimized Regional Recycling

22

- MRF-Municipal Contracting Best Practices
- Quality monitoring of materials
  - Inbound audits
  - Curbside feedback

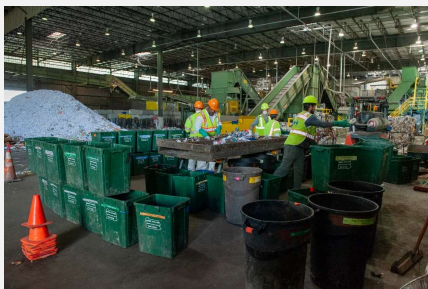

## Governance

23

- Regional Authority?
- Merging SWMDs?
- Public/Private Partnership?

## Summary of Big Decisions

24

Governance

Processing  
capacity

# Organics Diversion

25

## Compost Facilities

26

- **Boston Mtn. SWMD**
  - Fayetteville
  - EcoVista
- **Benton Co. SWMD**
  - City of Bentonville
  - Benton Co. SWMD



Source: 2019 Annual Report

## Estimated Regional Generation

27

- Residential Households
- Restaurants/Food Service
- Food Manufacturers/Processors
- Food Wholesale & Retail
- Hospitals & Assisted Living Facilities
- Educational Institutions
- Hospitality Industry

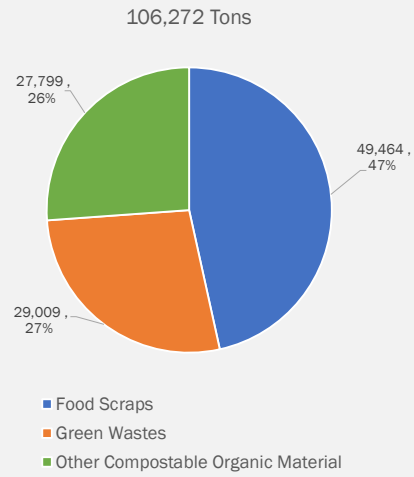

Based on regional waste comp. studies, current diversion & est. generation by population

## Organics Collection

28

- Fayetteville organics collection



- Other methods



## Financial Estimate for Regional Compost Facility

29

### One Regional Turned Windrow Compost Facility

Acres	9
Capital Cost	\$1,500,000
Annual Cost	\$650,000
Compost Revenue	-\$125,000
Net Annual Cost	\$525,000
Tons of Food Waste & Yard Waste	22,000
Per Ton	\$24

*Design Capacity: 10,000 tons/year food waste + 12,000 tons/year yard waste*

## Summary of Big Decisions

30

**Regionally  
Directed or  
Regionally  
Supported**

**Processing  
Capacity:  
Local or  
Regional**

# Construction & Demolition (C&D) Debris Diversion

31

## Overview of Conditions

32

- Growth & renovation has resulted in a lot of C&D waste in NWA
- Est. 92,000 tons/year



Eco-Vista Landfill - >77,000 tons in Class 4 (2018)

- Current management





## Recyclable C&D

33



## Strategies with No Regulatory Implications

34

- Outreach and Education
- Technical Assistance
- Recycled Content Requirements

## Strategies Requiring Policies/Regulatory Change

35

- Planning Requirements
- Reporting Requirements
- Diversion Requirements
- Deconstruction Requirements
- Recycling Deposits for Developers
- Economic Incentives for Haulers
- Processing Requirements/Landfill Ban
- Market Development

## Mixed C&D Processing

36

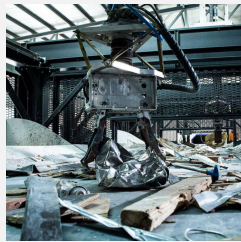

ZenRobotics  
High-Tech  
Options

### Estimate for Basic Elements

Asset	Capital Cost
Facility (35,000-40,000 sq.ft.)	\$1,500,000
Scale	\$100,000
Crusher	\$850,000
Shaker Plant or Trommel	
Screen	\$750,000
Conveyors	\$400,000
Magnet	\$75,000
Large Excavator	\$400,000
Small Excavator or Skid Steer	\$30,000
Wheel Loader	\$350,000
Layout & Design	\$50,000
Grinder (wood waste)	\$750,000
<b>Total</b>	<b>\$5,255,000</b>

## C&D Recommendations

37

- Create advisory group
- Gather building permit data
- Compile disposal reports
- Expand SWMD role
  - Budget to support C&D initiatives
  - Set diversion goals
  - Implement reporting and measurement system
  - Provide technical assistance

## Local Govt. Role

38

- Support the SWMD to assure information is available
- Establish or enhance recycled-content requirements for publicly funded projects
- Implement planning and reporting requirements as part of permitting process
- Establish city-specific policies and ordinances

## Next Steps

39

## Immediate

40

- Survey monkey to meeting stakeholders for prioritization
- Finalize Action Plan section of Plan
- Finalize Waste Reduction & Recycling Plan

## Moving Forward

41

- Standardize regional acceptable recyclables
- Districts become subject matter experts to provide contracting technical assistance
- Engage stakeholders on routine, ongoing basis

## Thank you

42

**John Culbertson, Principal**  
407/380-8951  
[jculbertson@mswconsultants.com](mailto:jculbertson@mswconsultants.com)

**Chas Jordan, Sr. Consultant**  
813/971-8333, x29  
[cjordan@kesconsult.com](mailto:cjordan@kesconsult.com)

**Cynthia Mormile, Sr. Project Manager**  
573/818-2281  
[cmormile@mswconsultants.com](mailto:cmormile@mswconsultants.com)

**Bethany Jewell, Consultant**  
813/971-8333, x15  
[bjewell@kesconsult.com](mailto:bjewell@kesconsult.com)

## Planning Requirements - Examples

43

C&D Recycling Plan Trigger	Example of a Threshold	Current Practice
Size of the Project	Greater than 10,000 sq ft.	San Diego (CA) specifies different square footage triggers for residential and commercial construction and renovation projects [1]
Cost of the Project	Greater than \$115,000 value	San Jose (CA) has separate thresholds for residential and commercial construction and renovation projects [2]
Amount of Waste to be Generated by Project	Greater than 10 tons	Chicago (IL) requires recycling of 50 percent of the weight of wastes generated [3]

## Reporting Requirements

44

		<b>Sector</b>	
		Residential	Non-residential
<b>Activity</b>	Construction ⇨	↓	↓
	Demolition ⇨		
	Renovation ⇨		
		<b>Data Needs:</b> Tonnage Project Value Composition/Recyclability	

## Diversion Requirements - Examples

45

Municipality	Diversion Requirement
Alameda County, CA	100% of concrete 50% of all other C&D debris
Portland, OR	Must provide source-separated recycling of wood, cardboard, green wastes, scrap metal, and rubble
Chicago, IL	50% of all "recyclable materials"

## Deconstruction Requirements

46



## Recycling Deposit Examples

47

City	Deposit	Range
Long Beach, CA	3 percent of project value	Min \$1,500, Max \$10,000
San Diego, CA	\$0.20 to \$0.70 per square foot	Min \$200, Max \$40,000
Plano, TX	\$0.15 to \$0.25 per square foot	Max \$11,250



---

# APPENDIX E

## STAKEHOLDER SURVEY RESULTS

---

This page intentionally left blank.



## **NWA Stakeholders Survey-Boston Mountain NWA Stakeholder Survey**

**Please answer the following questions to the best of your knowledge. We appreciate your participation in this survey.**



## NWA Stakeholders Survey-Boston Mountain Regional Recycling - Section 1

1.1 What jurisdiction (city, county, etc.) do you represent as a stakeholder of Northwest Arkansas solid waste management planning?

	Benton County	Madison County	Washington County
Cities	<input type="text"/>	<input type="text"/>	<input type="text"/>

Other (please specify)

## 1.2 Which of the following steps would you support to move toward standardized regional recycling?

	Highly Support	Moderately Support	Neutral	Somewhat Against	Strongly Against
Creating uniform branding and messaging about recycling across the region	<input type="radio"/>	<input type="radio"/>	<input type="radio"/>	<input type="radio"/>	<input type="radio"/>
Using technical assistance from the SWMDs to make sure trash and recycling collection contracts are structured to encourage a more regional recycling system.	<input type="radio"/>	<input type="radio"/>	<input type="radio"/>	<input type="radio"/>	<input type="radio"/>
Gradually changing to one regionwide curbside recycling system, if consensus is for a collection system different than your current one.	<input type="radio"/>	<input type="radio"/>	<input type="radio"/>	<input type="radio"/>	<input type="radio"/>
Committing your curbside and/or drop-off recycling tonnage to be delivered to a regional Material Recovery Facility under clear contractual terms and fee/rebate structure?	<input type="radio"/>	<input type="radio"/>	<input type="radio"/>	<input type="radio"/>	<input type="radio"/>

**1.3 Would you support the establishment of a regional recycling authority to oversee regional recycling processing and possibly related services?**

Yes

No

**1.4 If a regionally directed (i.e., owned by the regional entity) Material Recovery Facility to process recyclables is developed, how should these responsibilities be funded?**

Not willing to commit additional funding

Per-capita assessment paid by the county and local governments

Processing fee

Other (please specify)



## NWA Stakeholders Survey-Boston Mountain

1.5 Please indicate your opinion on the importance of the established Authority having the following responsibilities:

	Very Important	Somewhat Important	Neutral	Unimportant
Provide uniform education, branding, and outreach about recycling in the region.	<input type="radio"/>	<input type="radio"/>	<input type="radio"/>	<input type="radio"/>
Provide technical assistance to local governments on contracting best practices.	<input type="radio"/>	<input type="radio"/>	<input type="radio"/>	<input type="radio"/>
Convene routine stakeholder engagement and coordination among local governments, institutions, and private sector organizations to continuously improve recycling.	<input type="radio"/>	<input type="radio"/>	<input type="radio"/>	<input type="radio"/>
Be granted the ability to develop and adopt acceptable regulatory measures to improve diversion.	<input type="radio"/>	<input type="radio"/>	<input type="radio"/>	<input type="radio"/>

**Very Important**

**Somewhat Important**

**Neutral**

**Unimportant**

**Engage in contracts with private sector entities to serve the region, such as the operation of processing facilities.**

**Undertake the investment and ownership of a regional recyclables processing facility.**

**Other (please specify)**





## NWA Stakeholders Survey-Boston Mountain

**1.6 If the region opts to develop regional recyclables processing capacity, what features do you believe are most important?**

	Very Important	Somewhat Important	Neutral	Unimportant
Lowest possible processing cost	<input type="radio"/>	<input type="radio"/>	<input type="radio"/>	<input type="radio"/>
Highest diversion of residentially generated cardboard, paper, and containers, which could include holding cities accountable for delivering clean	<input type="radio"/>	<input type="radio"/>	<input type="radio"/>	<input type="radio"/>
Close proximity of facility(ies) to minimize drive time for collection trucks	<input type="radio"/>	<input type="radio"/>	<input type="radio"/>	<input type="radio"/>
Ability to accept source-separated materials	<input type="radio"/>	<input type="radio"/>	<input type="radio"/>	<input type="radio"/>
Ability to accept dual stream	<input type="radio"/>	<input type="radio"/>	<input type="radio"/>	<input type="radio"/>
Ability to accept single stream materials	<input type="radio"/>	<input type="radio"/>	<input type="radio"/>	<input type="radio"/>
Other (please specify)	<input type="text"/>			



## NWA Stakeholders Survey-Boston Mountain Regional Organics Diversion - Section 2

**2.1 Would you support your solid waste district undertaking the following responsibilities (check all that apply)?**

	Yes	No
Provide technical assistance to local governments on organics collection and composting best practices	<input type="radio"/>	<input type="radio"/>
Provide uniform education, branding, and outreach associated with organics diversion	<input type="radio"/>	<input type="radio"/>
Convene routine stakeholder engagement and coordination among local governments, institutions, and private sector organizations	<input type="radio"/>	<input type="radio"/>
Be granted some ability to develop and adopt regulatory measures to improve diversion	<input type="radio"/>	<input type="radio"/>
Engage in contracts with private sector entities to serve the region in part or in entirety	<input type="radio"/>	<input type="radio"/>
Undertake the investment and ownership of a regional composting facility	<input type="radio"/>	<input type="radio"/>

**Other (please specify)**

**2.2 If a regionally directed (i.e., owned by the regional entity) compost facility is developed, how should these responsibilities be funded?**

- Not willing to commit additional funding
- Per-capita assessment paid by the county and local governments
- Processing fee
- Other (please specify)

\_\_\_\_\_



## NWA Stakeholders Survey-Boston Mountain Regional C&D Diversion - Section 3

### 3.1 Would you support your solid waste district undertaking the following responsibilities?

	Yes	No
Set C&D diversion goals	<input type="radio"/>	<input type="radio"/>
Provide technical assistance and routine outreach to developers, contractors, haulers, and local governments on C&D diversion best practices	<input type="radio"/>	<input type="radio"/>
Implement reporting and measurement systems and requirements that may span haulers, disposal facilities, and local government building and zoning departments	<input type="radio"/>	<input type="radio"/>
Be granted the ability to develop and adopt regulatory measures to improve diversion of C&D debris	<input type="radio"/>	<input type="radio"/>
Enter a regional contract for the processing of mixed C&D debris from public sector construction, demolition, and renovation projects	<input type="radio"/>	<input type="radio"/>

### 3.2 How should these responsibilities be funded?

- Not willing to commit additional funding
- Per-capita assessment paid by the county and local governments
- Processing fee
- Other (please specify)







**NWA Stakeholders Survey-Boston Mountain**  
**Thank you for your Input.**

This page intentionally left blank.





11875 High Tech Avenue, St. 150, Orlando, FL 32817  
800.679.9220 | [mswconsultants.com](http://mswconsultants.com)